

capdell

Catalogue / Catálogo

capdell

Calle Flora Tristán, 24, 46970 Alaquàs,
Valencia

+34 961 502 950

info@capdell.com



capdell

Unique pieces / *Piezas únicas*

Everyone is different. We all have different experiences, we've faced different challenges, achieved different successes. If you study the world around you, focus through the haze of the rush and the broad strokes, you can find these differences in tiny details.

What is surprising is that these tiny details and differences are what make people stand out from the crowd, they are expressions of our personalities and our humanity.

Craftsmanship is an art that has existed since the beginning of humanity, but in a world where industrialisation has produced uniformity the craftsman is ever more important, he adds innovation, quality, attention to detail, individuality. It's knowledge that passes from person to person, generation to generation, enriched over time.

At Capdell, this knowledge has been evolving for more than 50 years and has allowed us to innovate, experiment, play and dream. We are always seeking to enhance the sensations that connect us with the product, the smell of wood, the warmth of the upholstery, the elegance of the design.

Working with extinguished and talented designers, among many others, we are able to give life to their visions in our Valencia factory allowing for strong and open communication at all stages of the process.

Our furniture carries the spirit of everyone at Capdell, from the hands that made them to the minds that designed them, each piece brings a little of each of us with it, make it into "unique pieces".

Cada persona con la que nos cruzamos en nuestro día es única y diferente. Las circunstancias y nuestra forma de afrontar las situaciones y retos nos marcan y definen, dejando ver la realidad que hay en cada uno.

Son estos pequeños detalles y diferencias los que hacen que las personas destaquen entre la multitud, son expresiones de nuestras personalidades y nuestra humanidad.

La artesanía es un arte que existe desde los inicios de la humanidad. En un mundo donde la industrialización ha producido uniformidad, el artesano es cada vez más importante, añade innovación, calidad, atención al detalle, individualidad. Es un conocimiento que se transmite de persona a persona, de generación en generación, enriquecido con el tiempo.

En Capdell, este conocimiento ha ido evolucionando durante más de 50 años y nos ha permitido innovar, experimentar, jugar y soñar. Siempre buscamos potenciar las sensaciones que nos conectan con el producto, el olor a madera, la calidez de la tapicería, la elegancia del diseño.

Trabajando con diseñadores con un reconocido prestigio internacional, somos capaces de dar vida a sus visiones e ideas en nuestra fábrica situada en Valencia.

Nuestros muebles llevan el espíritu de todo el equipo Capdell, desde las manos que los hicieron hasta las mentes que los diseñaron, cada pieza trae consigo un poco de cada uno de nosotros, convirtiéndose en "piezas únicas".

Designers / Diseñadores



Carlos Tiscar



Claesson | Koivisto | Rune



Fiorenzo Dorigo



Francesc Rifé



Fran Silvestre



Gabriel Teixidó



Isidro Ferrer



Kazuko Okamoto



Luca Nichetto



Lucy Kurrein



Marcel Sigel



Mario Ruiz



Patrick Norguet



Salvador Villalba



Sebastian Herkner



Vicent Martínez



Vicente Soto



Yonoh

Our values / Nuestros valores

craftwork / artesanía

Where industrialisation has produced uniformity the craftsman adds innovation, quality, attention to detail, individuality. Our knowledge has been evolving for more than 50 years and has allowed us to innovate, experiment, play and dream.

We are always seeking to enhance the sensations that connect us with the product.

Mientras la industrialización ha creado productos uniformes el artesano agrega innovación, calidad y atención al detalle, individualidad.

Nuestro conocimiento ha ido evolucionando durante más de 50 años, esto nos ha permitido innovar, experimentar, jugar y soñar. Buscamos siempre potenciar las sensaciones que nos conecten con el producto.

sustainability / sostenibilidad

In the manufacture of our products we only use renewable, recycled and 100% recyclable materials. Once the life of our product is over, its components can be easily separated for recycling. We optimize our production to improve our environmental efficiency. Reliability, durability and easy repair. Our furniture is made to last, for which we give a guarantee of 5 years.

En la fabricación de nuestros productos sólo empleamos materiales renovables, reciclados y 100% reciclables. Una vez finalizada la vida de nuestro producto sus componentes pueden separarse fácilmente para su reciclado. Optimizamos nuestra producción para mejorar nuestra eficiencia ambiental. Fiabilidad, duración y fácil reparación. Nuestros muebles están hechos para durar por ellos damos una garantía de 5 años.

innovation / innovación

We analyze the latest trends to provide customers with current products and finishes. We optimize the structures of our products so that they are as resistant as possible with the least amount of material.

We are in the continuous search for improvement to provide the best to our costumers and partners.

Analizamos las últimas tendencias para aportar a los clientes productos y acabados actuales. Optimizamos las estructuras de nuestros productos para que sean los más resistentes posible con la menor cantidad de material. Estamos en la continua búsqueda de la mejora para aportar lo mejor a nuestros clientes y partners.

design / diseño

We bet on design. For this reason, each of our pieces has a unique and differentiating design.

We work with nationally and internationally renowned designers.

We apply the latest trends to provide the market with the most groundbreaking and current designs.

Apostamos por el diseño. Por ello cada una de nuestras piezas tiene un diseño único y diferenciador.

Trabajamos con diseñadores de renombre nacional e internacional.

Aplicamos las últimas tendencias para proporcionar al mercado los diseños más rompedores y actuales.

Seat and stools /
Asientos y
taburetes



12 A-COLLECTION
by Fran Silvestre



20 ARO
by Carlos Tíscar



30 ATRIA
by Gabriel Teixidó



40 AVA
by Carlos Tíscar

New / Nuevo



48 CAPITA
by Fiorenzo Dorigo



54 CÉCILE
by Mario Ruiz



64 COL
by Francesc Rifé



72 CONCORD
by Claesson Koivisto Rune



84 DUAL
by Carlos Tíscar

New / Nuevo



90 ECO
by Carlos Tíscar



98 FLICK
by Vicente Soto



102 HELIUM
by David Redondo



110 ICONICA
by Gabriel Teixidó

New / Nuevo

New / Nuevo



118 ICS
by Fiorenzo Dorigo



124 ISA
by Vicent Martínez



130 LOOP
by Patrick Norguet



138 MARIETA
by Yonoh



150 MARTA
by Gabriel Teixidó



158 MATCH
by Patrick Norguet



164 MOON
by Gabriel Teixidó



176 NARA
by Mario Ruiz



184 NIX
by Patrick Norguet

New / Nuevo



194 PANEL
by Lucy Kurrein



202 POLO
by Yonoh



208 STIR
by Kazuko Okamoto



214 ULIS
by Sebastian Hekner



228 WEDGE
by Marcel Sigel

New / Nuevo

Sofas /
Sofás



234 ATOLL
by Fiorenzo Dorigo



240 BOLERO
by Claesson Koivisto Rune



248 BRIDGE
by Vicente Soto



256 DROPLETS
by Claesson Koivisto Rune

New / Nuevo



264 INSULA
by Patrick Norguet



272 NODAL
by Luca Nichetto



282 PLUM
by Claesson
Koivisto Rune



290 VISION
by Fiorenzo Dorigo

Tables /
Mesas



298 ABLE
by Fiorenzo Dorigo



304 ARO
by Carlos Tíscar



310 ATRIA
by Gabriel Teixidó



316 BASIC TABLES
by Capdell

New / Nuevo



322 DROPLETS
by Claesson Koivisto Rune



328 GUS
by Francesc Rifé



336 GAZELLE
by Claesson Koivisto Rune



342 INSULA
by Patrick Norguet



348 LIBRIS
by Vicent Martínez



360 NOOK
by Mario Ruiz



372 MESANA
by Salvador Villalba



378 MESANA DESK
by Patrick Norguet



384 TRISTAR
by Claesson
Koivisto Rune



390 W
by Gabriel Teixidó

SEAT AND STOOLS /
ASIENTOS Y TABURETES



A collection

Design by Fran Silvestre

EN Collection of chairs, armchairs, barstools and armchairs with straight lines of great visual lightness. Formed by the union of two elements, metal and wood, which together provide warmth and ergonomics. Designed by the architect Fran Silvestre, conceived as a sculptural piece for common spaces, hotels, restaurants, homes.

The steel tube structure is available in different colors, as well as the oak shell or, upholstered version for greater comfort.

Due to the characteristics of the metal and wood that compose it, they can be recycled, contributing to the circular economy.

ES Colección de sillas, sillones, taburetes y butacas de líneas rectas de gran ligereza visual. Formada por la unión de dos elementos, metal y madera, juntos aportan calidez y ergonomía. Diseñada por el arquitecto Fran Silvestre, concebida como pieza escultórica para espacios comunes, hoteles, restaurantes y hogares.

La estructura de acero esta disponible en diferentes colores así como la carcasa en roble o versión tapizada para mayor comodidad.

Debido a las características del metal y la madera que la componen pueden ser reciclados contribuyendo a la economía circular.

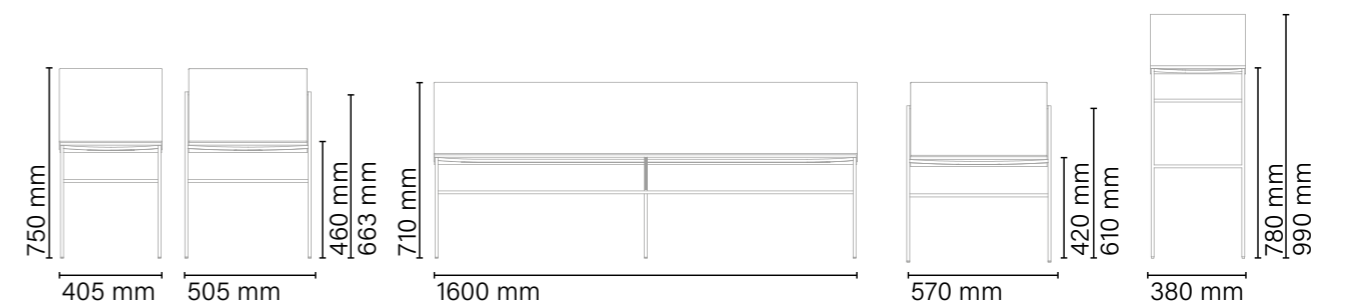







A collection

Chair / Sillas



460P
 Upholstered chair with oak shell and solid steel structure / Silla tapizada con carcasa de roble y estructura de acero



460R
 Oak wood chair with solid steel structure / Silla con carcasa de roble y estructura de acero



462P
 Upholstered armchair with oak shell and solid steel structure / Sillón tapizado con carcasa de roble y estructura de acero



462R
 Oak wood armchair with solid steel structure / Sillón con carcasa de roble y estructura de acero

Lounge & bench / Butaca & banco



464P
 Upholstered lounge chair with oak shell and solid steel structure / Butaca tapizada con carcasa de roble y estructura de acero



464R
 Oak wood lounge chair with solid steel structure / Butaca con carcasa de roble y estructura de acero



465P
 Upholstered bench with oak shell and solid steel structure / Banco tapizado con carcasa de roble y estructura de acero



465R
 Oak wood bench with solid steel structure / Banco con carcasa de roble y estructura de acero

Stool / Taburete



469P
 Upholstered stool with oak shell and solid steel structure / Taburete tapizado con carcasa de roble y estructura de acero



469R
 Oak wood stool with solid steel structure / Taburete con carcasa de roble y estructura de acero



ARO collection

Design by Carlos Tíscar

EN Aro is a collection with a timeless, comfortable and enveloping design, which reinterprets the round seat typology, referring to traditional cabinetmaking. //With the common denominator of the circle through which various elements such as chairs, armchairs, stools and side tables are achieved.

The warmth of the wood and its upholstered versions make it a perfect option for a wide variety of spaces in hotels, restaurants, work environments, home.

Made with PEFC sustainable wood, it can be recycled promoting the circular economy.

ARO LOW TABLES PAGE 304

ES Aro es una colección con un diseño atemporal, cómoda y envolvente, que reinterpreta la tipología de asiento redondo, evocando a la ebanistería tradicional.

Con el círculo como denominador común de la colección se consiguen diversos elementos como sillas, butacas, taburetes y mesitas auxiliares.

La calidez de la madera y sus versiones tapizadas, la convierten en una opción perfecta para gran variedad de espacios en hoteles, restaurantes, entornos de trabajo, hogar.

Fabricada con maderas sostenibles PEFC, esta puede ser reciclada fomentando la economía circular.

MESITAS ARO PÁGINA 304

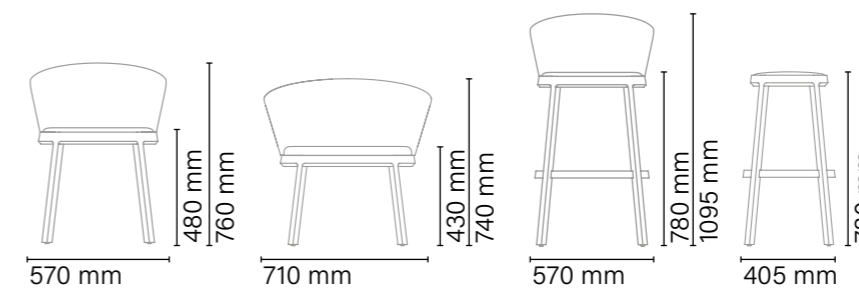

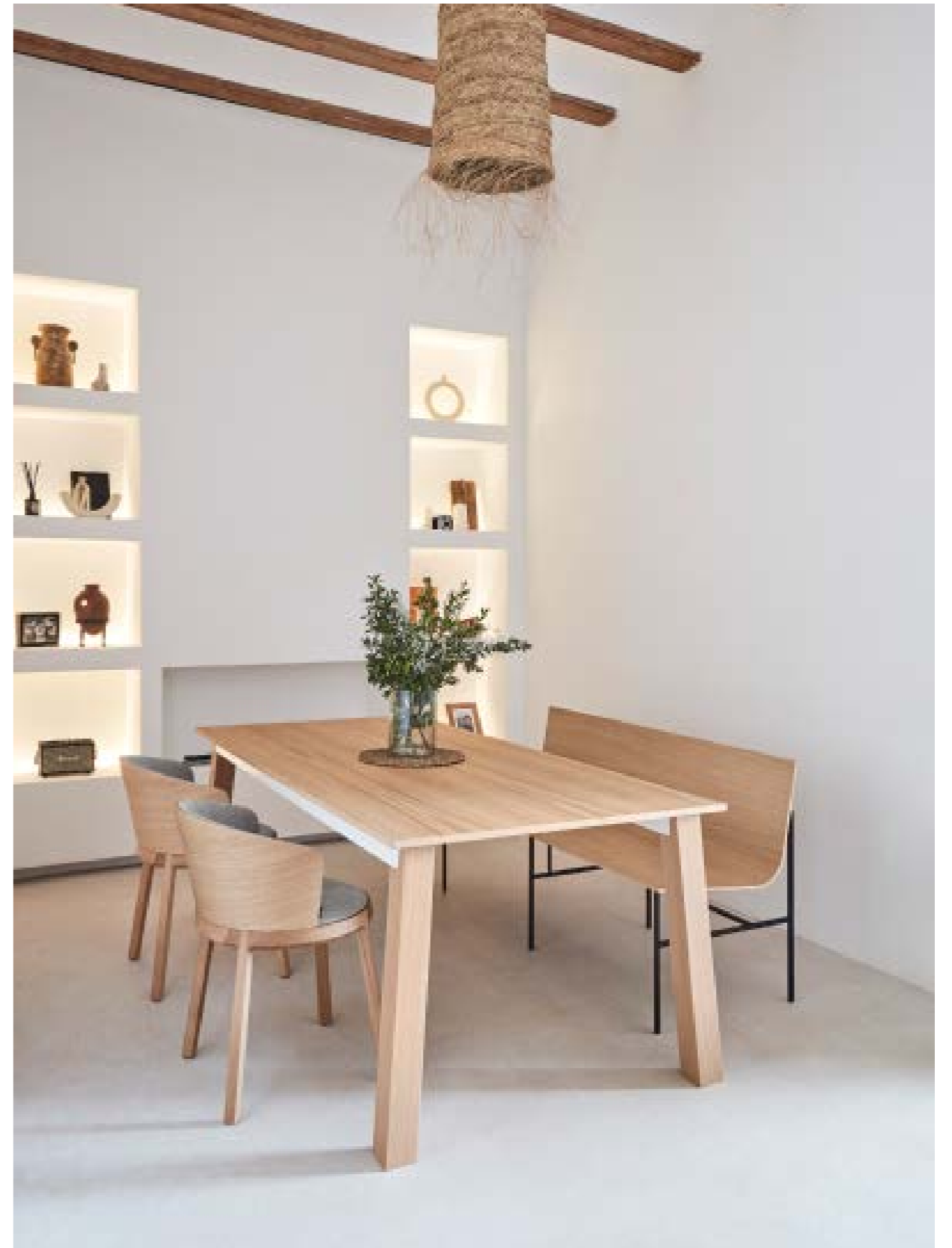







ARO collection

Chair / Sillas



691T
Upholstered armchair with beech or oak wood base / Silla tapizada con base de madera de roble o haya



691M
Semi upholstered armchair with beech or oak wood base and backrest / Silla semitapizada con base y respaldo de madera de roble o haya

Lounge / Butaca



695T
Upholstered lounge chair with beech or oak wood base / Butaca tapizada con base de madera de roble o haya



695M
Semi upholstered lounge chair with beech or oak wood base and backrest / Butaca semitapizada con base y respaldo de madera de roble o haya

Stool / Taburete



699
Upholstered stool with solid beech or oak wood base / Taburete tapizado con base de madera maciza de haya o roble



699H65
Upholstered stool with solid beech or oak wood base / Taburete tapizado con base de madera maciza de haya o roble



691TH78
Upholstered stool with solid beech or oak wood base / Taburete tapizado con base de madera maciza de haya o roble



691MH78
Semi upholstered stool with solid beech or oak wood base and backrest / Taburete semi tapizado con base y respaldo de madera maciza de haya o roble



capdell

ATRIA collection

Design by Gabriel Teixidó

EN Atria is a collection of seats that includes a chair, an armchair and a lounge chair. Its soft and light shapes emanate the warmth of the materials, solid oak for the structure and leather for the seat and back. The detail of the seam at the ends of the seat and backrest stands out, and the braiding that tightens the leather in the lower part. Its name refers to the atrium of Roman houses, around which the social life of the house revolved. It also means the brightest star.

ES Atria es una colección de asientos, compuesta por silla, silla con brazos y butaca. Sus formas suaves y ligeras emanan la calidez de los materiales, el roble macizo para la estructura y cuero en asiento y respaldo.

Destaca el detalle de la costura en los extremos del asiento y el respaldo, y el trenzado que tensa el cuero en la parte baja.

Su nombre hace referencia al atrio de las viviendas romanas, en torno al cual giraba la vida social de la casa. También significa la estrella que más brilla.

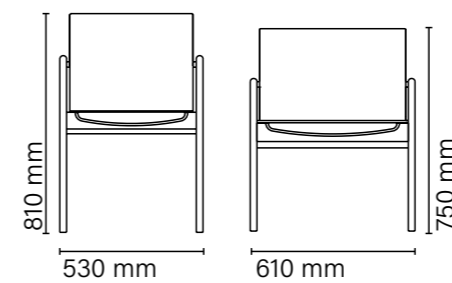

capdell









ATRIA collection

Chair / Sillas



2323

Oak wood stained arm chair with traditional upholstered of premium leather / Silla con brazos y sin brazos Atria, estructura de madera de roble teñida en S80 con tapizado tradicional de cuero premium



2322

Oak wood stained chair with traditional upholstered of premium leather / Silla con brazos y sin brazos Atria, estructura de madera de roble con tapizado tradicional de cuero premium



2325

Oak wood stained lounge chair with traditional upholstered of premium leather / Butaca con estructura de madera de roble con tapizado tradicional de cuero premium



AVA collection

Design by Carlos Tíscar

EN Ava is a collection of chairs and armchairs with a versatile and timeless design. Solid beech wood frame. The beveled legs create a visual effect of lightness by playing with the volumetry depending on the angle from which it is viewed. The backrest and seat are upholstered and adapt to the shapes of the body to provide great comfort.

Ideal for projects that require a durable and resistant chair such as hotels, restaurants, home.

Made with PEFC sustainable wood and easily recycled.

ES Ava es una colección de silla y sillón con un diseño versátil y atemporal. De estructura de madera de haya maciza. El biselado de las patas crea un efecto visual de ligereza jugando con la volumetría en función del ángulo del que se observe. El respaldo y asiento están tapizados y se adaptan a las formas del cuerpo para proporcionar un gran confort.

Ideal para proyectos que requieran una silla duradera y resistente como hoteles, restaurantes, hogar.

Fabricada con maderas sostenibles PEFC y de fácil reciclado.

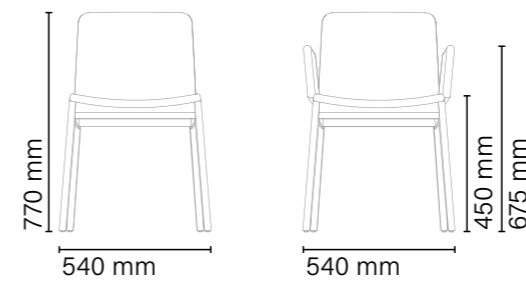

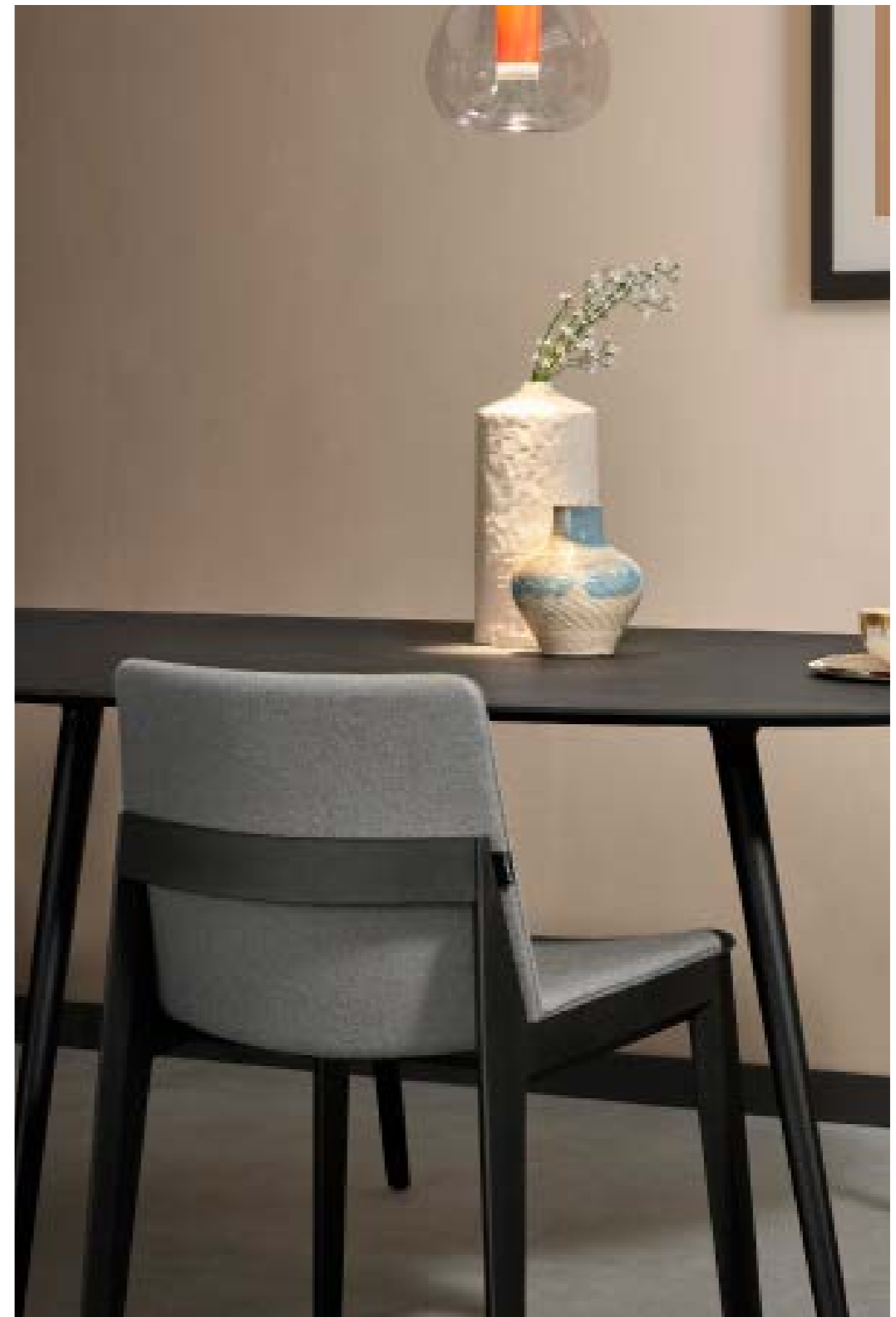





AVA collection

Chair / Silla



646

Upholstered chair with beech wood base / Silla tapizada con base de madera de haya



646N

Upholstered armchair with beech wood base / Sillón tapizado con base de madera de haya



CAPITA collection

Design by Fiorenzo Dorigo

EN Elegant and versatile, Capita is a wide beech chair, which reclaims its space almost as if it were an armchair, and at the same time, has a light and warm appearance, thanks to the joinery work and its fine seat, which seems to float above the structure.

Composed of chair and armchair with footrest. With a PEFC sustainable solid wood structure, smooth contours with ergonomic seat and backrest that provide high comfort and durability.

Due to its design, it works well alone or combined, either at home and in hotels, restaurants or common areas.

ES Elegante y polivalente, Capita es una silla de haya de porte ancho, que reclama su espacio casi como si se tratara de un sillón, y al mismo tiempo, tiene un aspecto ligero y cálido, gracias al cuidadoso trabajo de la madera y a su fino asiento, que parece flotar sobre la estructura.

Compuesta por silla y butaca con reposapiés. Estructura de madera maciza sostenible PEFC, de suaves contornos con asiento y respaldo ergonómicos que proporcionan un alto confort y durabilidad.

Por su diseño, funciona bien sola o en conjunto, tanto en hogar como en hoteles, restaurantes o zonas comunes.

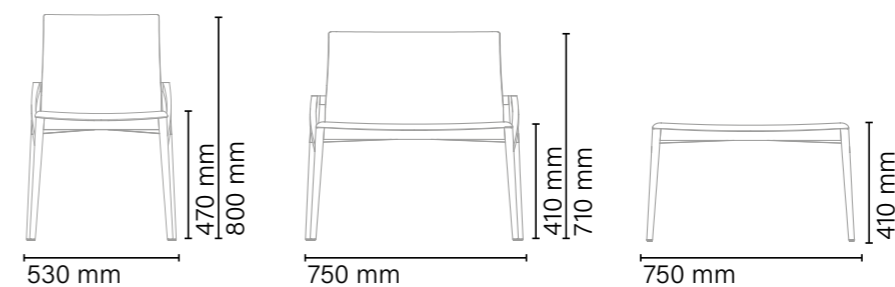





CAPITA collection

Chair / Sillas



510T

Upholstered chair with beech wood base / Silla tapizada con base de madera de haya

Lounge / Butaca



511T

Upholstered lounge chair with beech wood base / Butaca tapizada con base de madera de haya

Restfoot / Reposapiés



512T

Upholstered restfoot with beech wood base / Reposapiés tapizado con base de madera de haya



54

CÉCILE collection

Design by Mario Ruiz

EN Cécile is a timeless design chair collection in organic and welcoming shapes, a wonderfully comfortable piece that praises craftsmanship, and with great adaptability to different scenarios and uses.

Its simplicity results in versatility to adapt to spaces of a very different nature, both in contract, in multipurpose spaces, in flexible and reconfigurable hybrid areas, and at home.

Despite its lightness, it is a chair with a robust identity, with a characteristic language of curves and counter-curves in a 36 mm diameter cylindrical structure with no visible joining elements. Consistent with the lines outlining the structure of the piece, the seat and backrest have a gentle curvature that envelops the body with balanced proportions.

The chair can be entirely made in wood, or with the seat and backrest upholstered combining various densities of polyurethane foam. In its metallic version, with painted steel tube, its appearance conveys the same warmth as the wooden version while maintaining its enveloping shapes and delivering an image of great comfort.

In addition to these two versions, there is also an outdoor Cécile with an aluminium structure, seat and backrest and the possibility of upholstery on the seat. All versions are stackable.

ES Colección de sillas de diseño atemporal, de formas orgánicas y acogedoras, Cécile es una pieza muy confortable que ensalza el trabajo artesanal y que tiene una gran capacidad de adaptación a diferentes escenarios y usos.

Su sencillez se traduce en versatilidad para adaptarse a espacios de muy diferente naturaleza, tanto en contract, en espacios polivalentes, híbridos flexibles y reconfigurables, así como en hogar.

Pese a su ligereza, se trata de una silla de identidad robusta, con un lenguaje característico de curvas y contracurvas en una estructura cilíndrica de 36 mm de diámetro sin elementos de unión vistos. En coherencia con las líneas que dibujan la estructura de la pieza, el asiento y el respaldo tienen también una suave curvatura que envuelve el cuerpo con unas proporciones equilibradas.

La silla puede ser totalmente en madera o con el asiento y respaldo tapizado combinando varias densidades de espuma de poliuretano. En su versión metálica, con tubo de acero pintado, su apariencia proyecta la misma calidez que la versión de madera y mantiene las formas envolventes transmitiendo una imagen de mucho confort.

Además de estas dos versiones, Cécile tiene también una versión de silla para exterior con estructura de aluminio, asiento y respaldo de aluminio con la posibilidad de tapizado en el asiento. En todas sus versiones se trata de una pieza apilable.

55

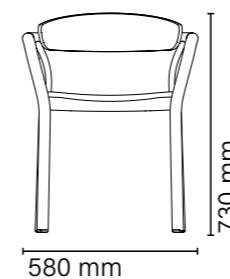









CÉCILE collection

Chair / Sillas



2341M

Chair with ash solid wood structure and seat and back of ash plywood / Silla con estructura de madera maciza de fresno y asiento y respaldo en madera contrachapada

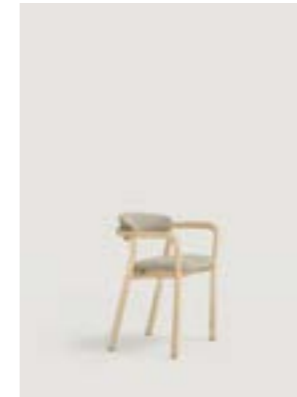

2341T

Chair with ash solid wood structure and seat and back upholstered / Silla con estructura de madera maciza de fresno y asiento y respaldo tapizado



2342M

Chair with metal structure and seat and back of ash plywood / Silla con estructura de metal y asiento y respaldo en madera contrachapada



2342T

Chair with metal structure and seat and back upholstered / Silla con estructura de metal y asiento y respaldo tapizados

Cécile Exterior



2341M-3

Chair with Iroko solid wood structure, seat and back / Silla con estructura, asiento y respaldo de madera maciza de Iroko



COL collection

Design by Francesc Rifé

EN A reinterpretation of the typical school chair of the 80s and 90s, Col is a collection of chairs made of curved steel tube, coated with epoxy paint, with curved oak laminate seat and back.

Its friendly and balanced shape make it a perfect option for work spaces, hospitality and home.

With a comfortable and completely timeless design, it is available in wood and upholstered versions.

ES Una reinterpretación de la típica silla de colegio de los años 80 y 90, Col es una colección de sillas de tubo de acero curvado, recubierto de pintura epoxi, con asiento y respaldo laminado de roble curvado.

Su forma amable y equilibrada la convierten en una opción perfecta para espacios de trabajo, hostelería y hogar.

Con un diseño cómodo y completamente atemporal, está disponible en versión madera y tapizada.

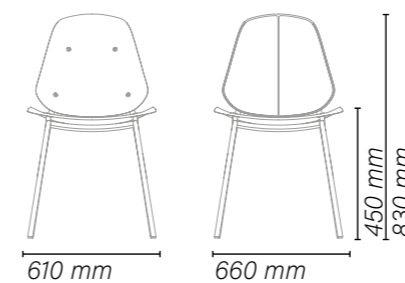



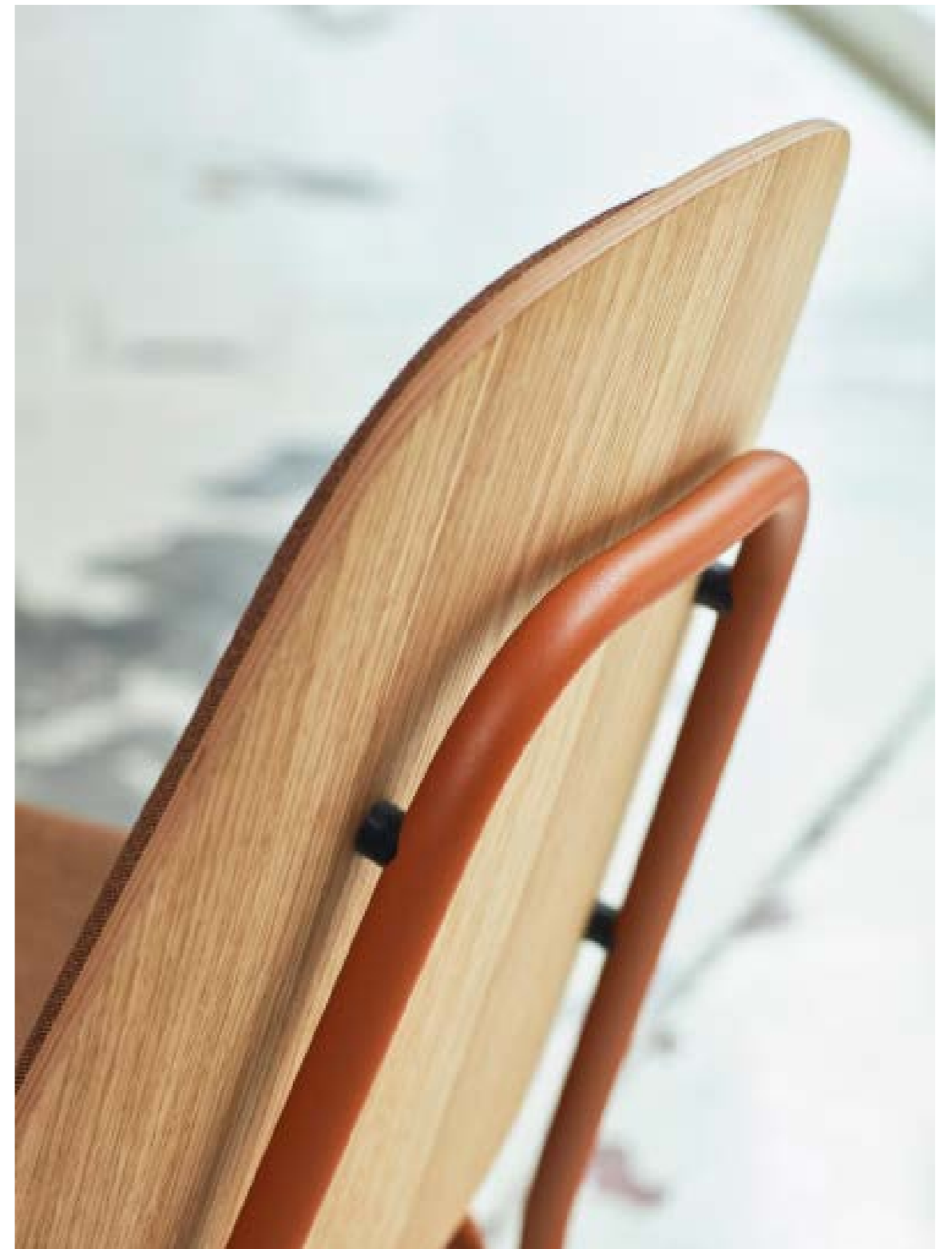



COL collection

Chair / Sillas



370M

Chair with oak veneer shell and steel structure / Silla con carcasa chapada en madera de roble y estructura de acero



370P

Upholstered chair with oak veneer shell and steel structure / Silla tapizada con carcasa chapada en madera de roble y estructura de acero



CONCORD collection

Design by Claesson Koivisto Rune

EN Inspired by the wonderful layers of the earth's atmosphere, those that can sometimes be seen at sunset or from an airplane.

The main feature of the Concord collection is its horizontal division into layers. The legs, support frame, seat, lower backrest/armrest, and upper backrest represent separate visual levels.

The Concord collection comprises a large number of variants based on the basic structure made up of one, two or three horizontal pieces of curved plywood that are combined in different sizes and finishes: upholstered, exposed wood or mixed combinations.

The base is available in different configurations, including beech or oak wood bases or aluminum bases. Perfect for residential use, restaurants, work spaces or common areas.

ES Inspirada en las maravillosas capas de la atmósfera terrestre, esas que a veces se pueden percibir al atardecer o desde un avión.

La característica principal de la colección Concord es su división horizontal en capas. Las piernas, el marco de soporte, el asiento, el reposabrazos o respaldo inferior y el respaldo superior representan niveles visuales separados.

La colección Concord comprende un gran número de variantes a partir de la estructura básica compuesta por una, dos o tres piezas horizontales de madera contrachapada curvada que se combinan en distintos tamaños y acabados: tapizados, madera vista o combinaciones mixtas.

La base está disponible en diferentes configuraciones, incluyendo bases de madera de haya o roble o bases de aluminio. Perfecta para uso residencial, restaurantes, espacios de trabajo o zonas comunes.

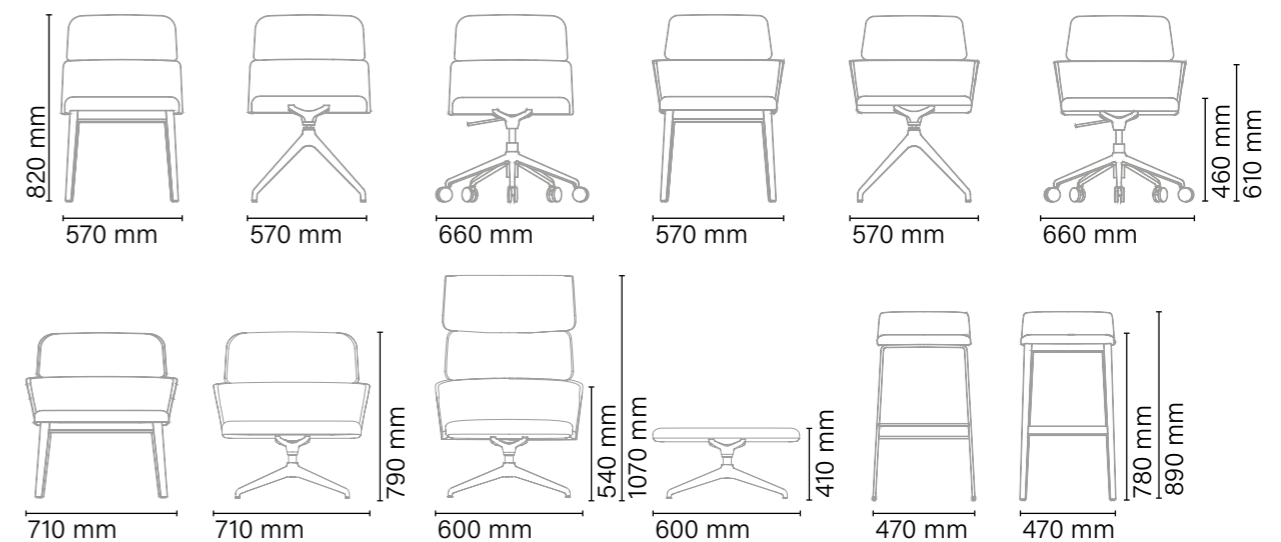



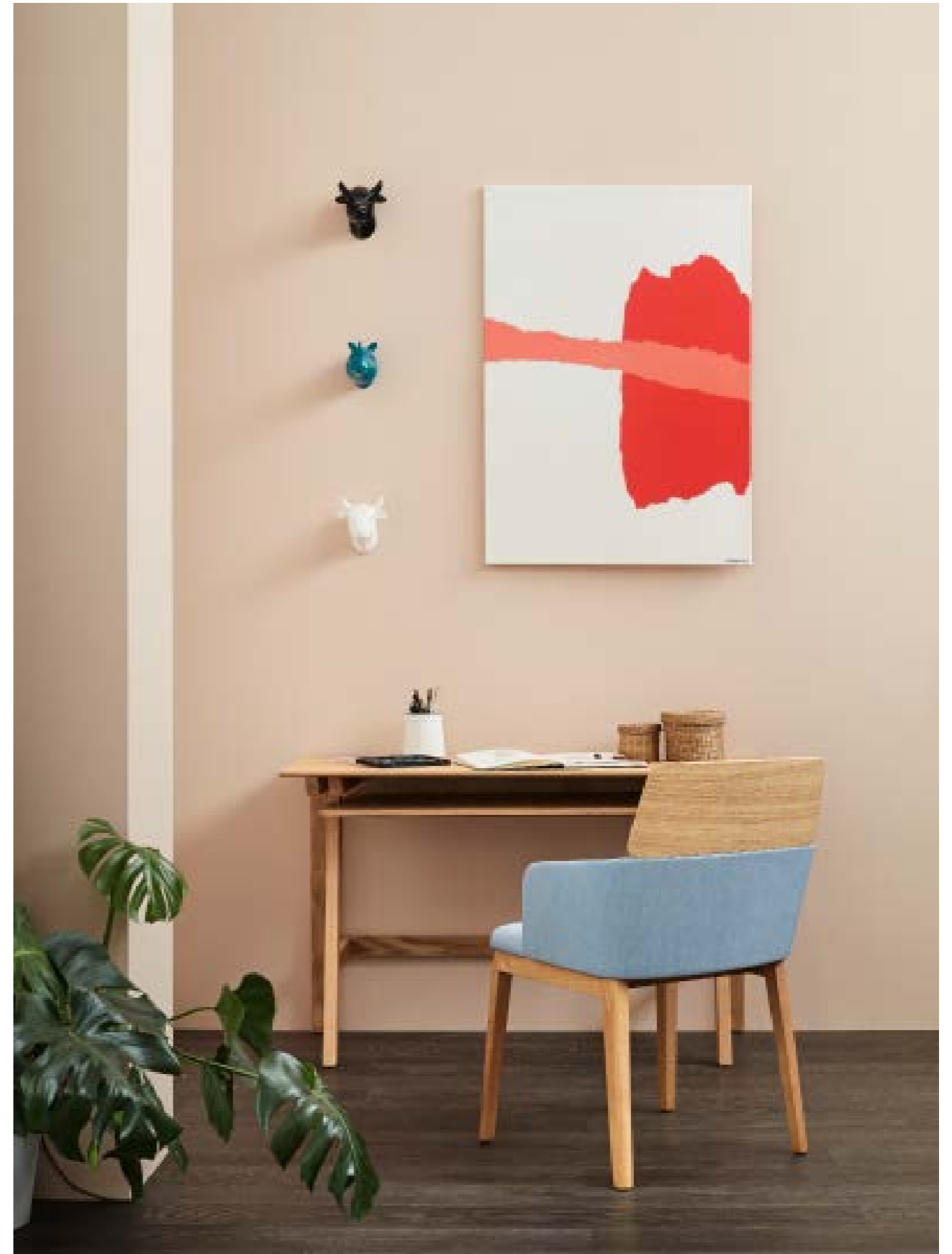





CONCORD collection

Chair / Sillas



522UM
Upholstered chair with beech or oak wood base / Silla tapizada con base de madera de haya o roble



522WM
Semi upholstered chair with beech wood or oak base and backrest / Silla semitapizada con base y respaldo de madera de haya o roble



522UD
Upholstered chair with aluminium base / Silla tapizada con base de aluminio



522WD
Upholstered chair with beech wood or oak backrest and aluminium base / Silla tapizada con respaldo de haya o roble y base de aluminio



522UDR
Upholstered chair with aluminium base fitted with castor wheels / Silla tapizada con base de aluminio equipada con ruedas



522WDR
Semi upholstered chair with aluminium base fitted with castor wheels / Silla semitapizada con base de aluminio equipada con ruedas



523UM
Upholstered armchair with beech or oak wood base / Sillón tapizado con base de madera de haya o roble



523WM
Semi upholstered armchair with beech wood or oak base and backrest / Sillón semitapizado con base y respaldo de madera de haya o roble

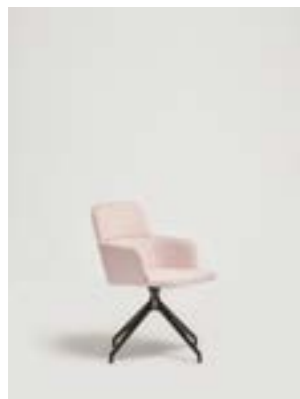

523UD
Upholstered armchair with aluminium base / Sillón tapizado con base de aluminio



523WD
Upholstered armchair with beech wood or oak backrest and aluminium base / Sillón tapizado con respaldo de haya o roble y base de aluminio



523UDR
Upholstered armchair with aluminium base fitted with castor wheels / Sillón tapizado con base de aluminio equipada con ruedas



523WDR
Semi upholstered armchair with aluminium base fitted with castor wheels / Sillón semitapizado con base de aluminio equipada con ruedas

Lounge / Butaca



525DB
Upholstered lounge chair with aluminium base / Butaca tapizada con base de aluminio



525UM
Upholstered lounge chair with beech or oak wood base / Butaca tapizada con base de madera de haya o roble



527DB
Upholstered lounge chair relax with aluminium base / Sillón relax tapizado con base de aluminio



528DB
Upholstered restfoot relax with aluminium base / Reposapiés tapizado con base de aluminio

Stool / Taburete



529M
Upholstered stool with beech or oak wood base / Taburete tapizado con base de madera de haya o roble

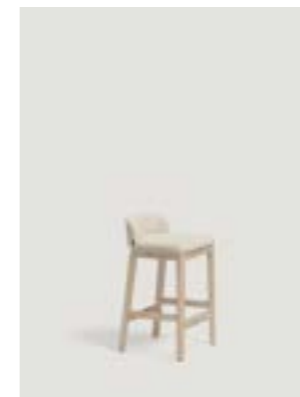

529M65
Upholstered stool with beech or oak wood base / Taburete tapizado con base de madera de haya o roble



529V
Upholstered barstool with solid steel structure / Taburete tapizado con estructura de varilla patin de acero



529M65
Upholstered barstool with solid steel structure / Taburete tapizado con estructura de varilla patin de acero

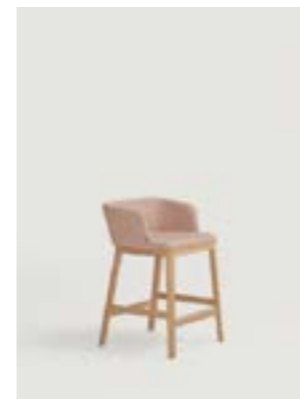

521MB65
Upholstered stool with beech or oak wood base / Taburete tapizado con base de madera de haya o roble



DUAL collection

Design by Gabriel Teixidó

EN Collection of benches and side tables with a light and elegant aesthetic. A minimalist design but with a presence that impacts the environment. The designers, the Claesson Koivisto Rune, were inspired by the shapes that droplets of water make when they land on a surface. The different models allow endless combinations that make this collection a set perfectly adaptable to common spaces, retail and hotels.

ES Colección de sillas de líneas sencillas, de gran confort, atemporal, tapizadas y con estructura de madera de haya maciza con certificado de sostenibilidad PEFC. Diseñada para ser fácilmente adaptada a espacios como restaurantes, hoteles o residencia. En esta pieza destaca el encuentro del tapizado con la madera en la parte frontal de la silla. La tela se superpone sobre el bastidor creando una dualidad de los materiales.

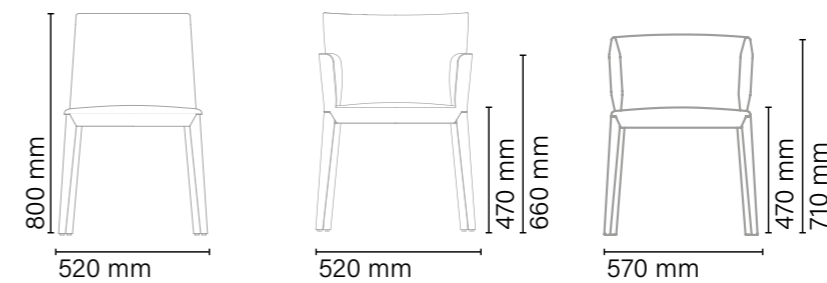





DUAL collection

Chair / Sillas



480B
 Upholstered chair with beech wood base / Silla tapizada con base de madera de haya



482
 Upholstered armchair with beech wood base / Sillón tapizado con base de madera de haya



483
 Upholstered armchair with beech wood base / Sillón tapizado con base de madera de haya



capdell

ECO collection

Design by Carlos Tíscar

EN The complex skeleton-like structure is the main feature of this model. It marks the personality of the chair and defines it as an almost sculptural object that, despite its bareness, is warm and welcoming due to its shape and the natural materials used in its construction.

The structure, without edges, transmits so much strength and stability that it seems to rise from the ground instead of resting on it.

ES La compleja estructura a modo de esqueleto constituye el rasgo principal de este modelo. Marca la personalidad de la silla y la define como un objeto casi escultórico, que a pesar de la desnudez, resulta cálido y acogedor por la forma y los materiales naturales empleados en su construcción.

La estructura, carente de aristas, transmite tanta fuerza y estabilidad que parece surgir del suelo en lugar de apoyarse sobre él.

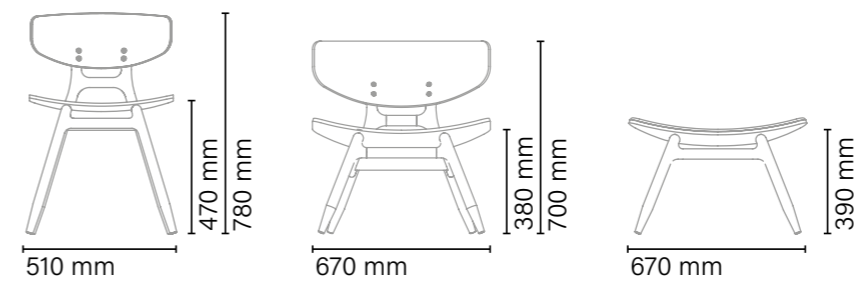

capdell







ECO collection

Chair / Sillas



500M

Chair with beech or oak wood base, restback and seat / Silla con estructura, respaldo y asiento de madera de haya o roble



500P

Semi upholstered chair with beech or oak wood base, restback and seat / Silla semitapizada con estructura, respaldo y asiento de madera de haya o roble



500T

Upholstered chair with beech or oak wood base / Silla tapizada con estructura, de madera de haya o roble

Lounge / Butaca



501M

Lounge chair with beech or oak wood base, restback and seat / Butaca con estructura, respaldo y asiento de madera de haya o roble



501P

Semi upholstered lounge chair with beech or oak wood base, restback and seat / Butaca semitapizada con estructura, respaldo y asiento de madera de haya o roble

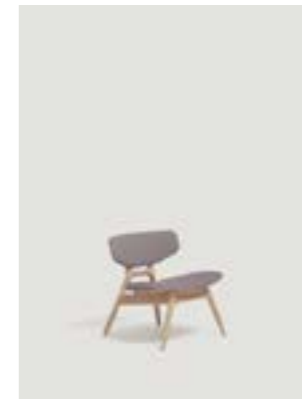

501T

Upholstered lounge chair with beech or oak wood base / Butaca tapizada con estructura, de madera de haya o roble

Restfoot / Reposapiés

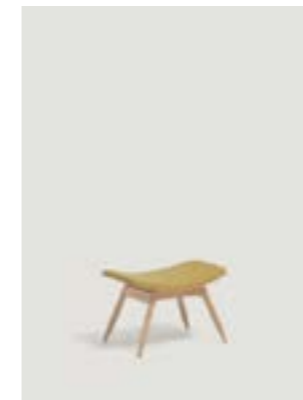

501REP

Semi upholstered restfoot with beech or oak wood base, restback and seat / Reposapiés semitapizada con estructura, respaldo y asiento de madera de haya o roble



FLICK collection

Design by Vicente Soto

EN From the search for perfection for the balance between aesthetics and functionality, the Flick collection is born.

A chair with an internal metal frame and flexible injected backrest and square metal legs available in different colours. With a strong and simple timeless aesthetic, it has proven to be an excellent choice, both for sophisticated and elegant home spaces, and for furnishing installations that require intensive use.

ES De la búsqueda de la perfección por el equilibrio entre estética y funcionalidad nace la colección Flick.

Una silla con una estructura interna metálica y respaldo inyectado flexible y patas cuadradas metálicas disponibles en diferentes colores. Con una estética intemporal robusta y sencilla, ha demostrado con la ser una excelente elección, tanto para espacios sofisticados y elegantes de hogar, como para el equipamiento de instalaciones que requieren de un uso intensivo.

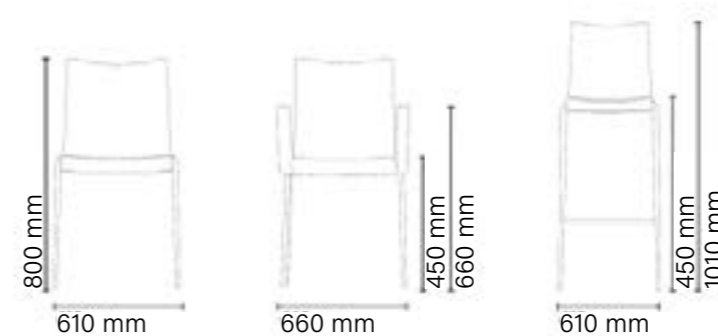



FLICK collection

Chair / Sillas



824C
Stackable chair with a metal base and injected foam shell / Silla apilable con estructura metálica y carcasa de espuma inyectada



824NC
Armchair with a metal base and injected foam shell / Sillón con estructura metálica y carcasa de espuma inyectada

Stool / Taburete



829C
Stackable stool with a metal base and injected foam shell / Taburete apilable con estructura metálica y carcasa de espuma inyectada



HELIUM collection

Design by David Redondo

EN Helium collection is unique and original design makes it an object that invites exploration and touch. Every detail has been carefully thought out to offer the user an incomparable experience.

The first contact with the chair is a sensation of comfort, thanks to its generous and protruding volumes. These volumes are inspired by the works of Jeff Koons and give the chair a commanding and distinctive presentation. However, its light and subtle appearance gives it a feeling of buoyancy, as if it were filled with helium.

ES Su diseño único y original la convierte en un objeto que invita a la exploración y al tacto. Cada detalle ha sido cuidadosamente pensado para ofrecer al usuario una experiencia incomparable.

El primer contacto con la silla es una sensación de comodidad, gracias a sus volúmenes generosos y protuberantes. Estos volúmenes están inspirados en las obras de Jeff Koons y le dan a la silla una presencia imponente y distintiva. Sin embargo, su apariencia liviana y sutil le otorga una sensación de flotabilidad, como si estuviera llena de helio.

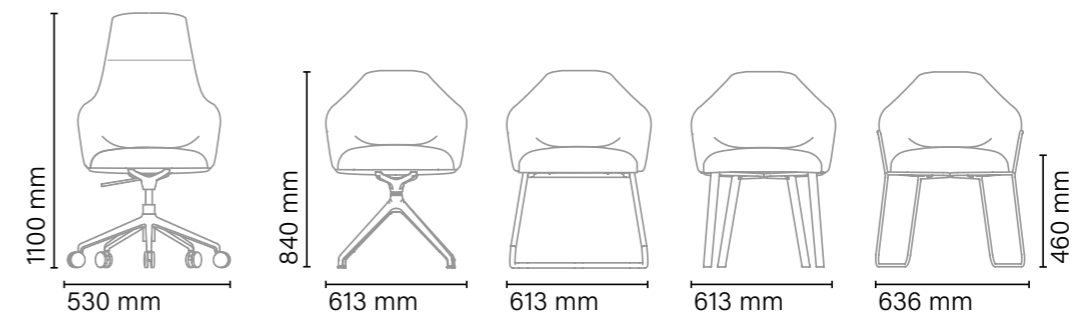



104



105





HELIUM collection

Chair / Sillas



2330PTN
Upholstered chair with metal base /
Silla tapizada con base de patin



2330DR
Upholstered chair with five swivel
aluminium base fitted with castor
wheels / Silla tapizada con base de
aluminio de cinco radios con ruedas



2330D
Upholstered chair with four swivel
aluminium base / Silla tapizada con
base giratoria de aluminio de cuatro
radios



2330CAN
Upholstered chair with metal canti-
leber base / Silla tapizada con base
de metal cantileber



2330TNS
Upholstered chair with solid steel
base / Silla tapizada con base de
varilla de acero de tensor



2330W
Upholstered chair with solid ash
base / Silla tapizada con base de
madera de fresno macizo



2331DR
Upholstered chair, high shell, with
five swivel aluminium base fitted
with castor wheels / Silla tapizada,
carcasa alta, con base de aluminio
de cinco radios con ruedas



2331D
Upholstered chair, high shell, with
four swivel aluminium base / Silla
tapizada, carcasa alta, con base de
aluminio de cuatro radios



ICONICA collection

Design by Gabriel Teixidó

EN The Iconica armchair is the result of the combination of aesthetics and functionality.

With a clear respect for tradition and local craftsmanship, it is upholstered with a braided system that uses top quality waterproof suede leather.

Its unique structure in solid beech wood is under PEFC certification, which guarantees that it comes from responsibly managed forests in accordance with the strictest environmental, social and economic requirements.

A piece that makes its presence impact the environment.

ES La butaca Iconica es el resultado de la combinación de estética y funcionalidad.

Con un claro respeto por la tradición y la artesanía local, está tapizada con un sistema trenzado que utiliza piel serraje impermeable de primera calidad.

Su estructura única en madera maciza de haya está bajo la certificación PEFC, que garantiza que procede de bosques gestionados de forma responsable de acuerdo con los más estrictos requisitos medioambientales, sociales y económicos.

Una pieza cuya presencia impacta en el entorno.

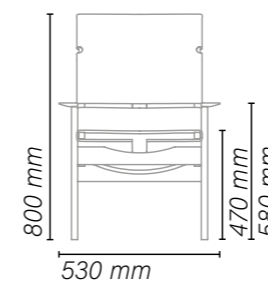







ICONICA collection

Lounge / Butaca



245V

Lounge chair with beech wood frame. Handcrafted upholstery with premium leather / Butaca con estructura de madera de haya. Tapizado artesanal de vaqueta



245S

Lounge chair with beech wood frame. Handcrafted upholstery with suede leather / Butaca con estructura de madera de haya. Tapizado artesanal de cuero afelpado.



245L

Lounge chair with beech wood frame. Upholstered using sailcloth, foam and fabric or leather / Butaca con estructura de madera de haya. Tapizada usando loneta, espuma y tela o piel.



ICS collection

Design by Fiorenzo Dorigo

ENA multi-purpose collection which emphasises the simple and sinuous design, materiality and attention to details.

The endless upholstery options and the use of various materials for the bases, such as wood or metal legs, make Ics chairs appropriate for the home as for multi-purposes spaces, adapting them to any atmosphere.

ES Colección polivalente que parte de una carcasa de estructura metálica revestida de poliuretano inyectado de gran resistencia, flexibilidad y ligereza visual. Sus tapizados y el uso de diversos materiales de soporte, como la madera y el metal, hacen de Ics un asiento adecuado para su uso en el hogar y en instalaciones, que se adapta a todos los ambientes, desde los más informales hasta los más sofisticados.

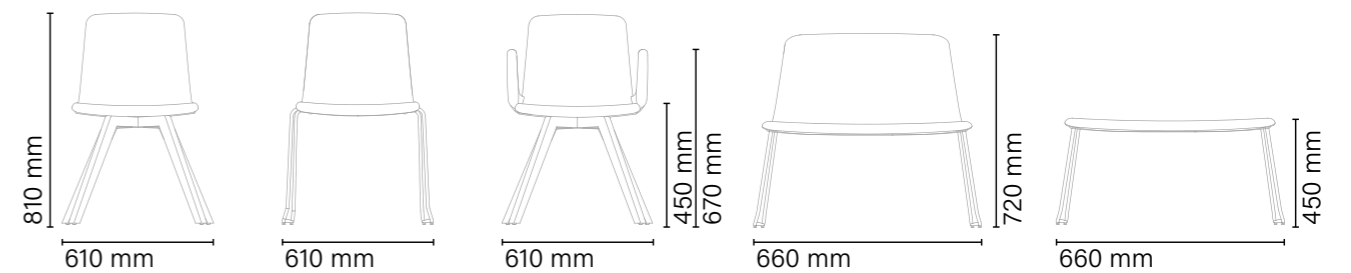



Seating /Asientos

capdell



capdell

Seating /Asientos



ICS collection

Chair / Sillas



505MD4

Upholstered chair with solid beech or oak wood base / Silla tapizada con base de madera maciza de haya o roble



505PTN

Chair with sled base in powder-coated steel or chrome finishing / Silla con estructura de patín con varilla de acero recubierta de pintura en polvo o cromada



506MD4

Upholstered armchair with solid beech or oak wood base / Sillón tapizada con base de madera maciza de haya o roble

Lounge / Butaca



507PTN

Lounge chair with sled base in powder-coated steel or chrome finishing / Butaca con estructura de patín con varilla de acero recubierta de pintura en polvo o cromada

Restfoot / Reposapiés



508PTN

Restfoot with sled base in powder-coated steel or chrome finishing / Reposapiés con estructura de patín con varilla de acero recubierta de pintura en polvo o cromada



ISA collection

Design by Vicent Martínez

EN Isa, is a chair full of symbolism and adaptability. Thanks to its lively and variable backrests, Isa transforms itself, something that allows it to be integrated into very diverse spaces. It manages to become a chair with many styles: Nordic, classic, Mediterranean, existential, sophisticated, linear or fresh. Its secret: the play of its beech backrest and upholstery. It is also stackable and a singular and small hole is created in the backrest that allows you to leave small bags, purses, wallets or laptops. Ideal for restaurant spaces.

The Isa collection was part of the Contemporary Icons exhibition. Sit Down Please! of the creative magazine NEO2, held in Madrid in 2020.

ES Isa, es una silla cargada de simbolismo y capacidad de adaptación. Gracias a sus formas, Isa se transforma, algo que le permite integrarse en espacios muy diversos, Consigue convertirse en una silla con muchos estilos: nórdica, clásica, mediterránea, existencial, sofisticada, lineal o fresca. Su secreto: el juego de su respaldo de haya y el tapizado. La silla es apilable y en el respaldo se crea un singular y pequeño hueco que permite dejar pequeños bolsos, monederos, carteras o portátiles. Ideal para espacios de restauración.

La colección Isa formó parte de la exposición de Iconos contemporáneos. Sit Down Please! de la creative magazine NEO2, celebrada en Madrid en 2020.

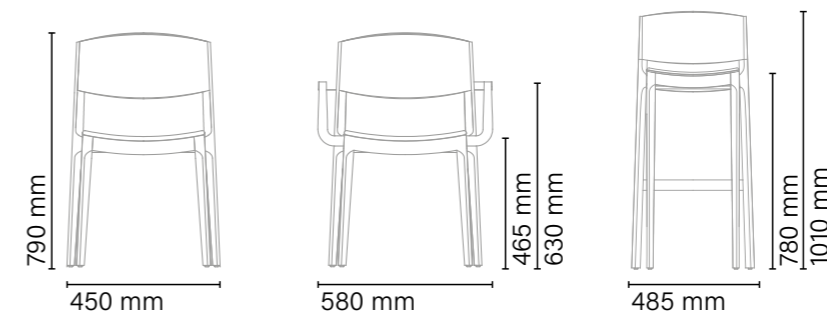





ISA collection

Chair / Sillas

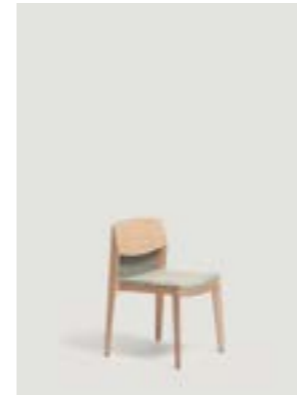

141
Semi upholstered chair with beech wood base and backrest / Silla semitapizada con base y respaldo de madera de haya o roble



141N
Semi upholstered armchair with beech wood base and backrest / Sillón semitapizado con base y respaldo de madera de haya o roble

Stool / Taburete



141B
Semi upholstered stool with beech wood base and backrest / Taburete semitapizado con base y respaldo de madera de haya o roble



LOOP collection

Design by Patrick Norguet

EN Loop is a family of chairs with a wide variety of customizable options. Contemplated for every type of spaces; residential, restaurants, work spaces. It is composed of a high wooden shell or low upholstered available in three bases to choose from with or without arms.

The shell upholstery can be soft or traditional and the arms, metallic or upholstered.

This chair have two types of upholstery: Traditional or soft.

ES La colección Loop ha sido concebida para proporcionar un confort máximo. Diseñada con formas ergonómicas que se adaptan perfectamente al contorno de la espalda, siendo perfecta como silla de trabajo. Loop es una familia de sillas con una gran variedad de opciones personalizables. Pensada para todo tipo de espacios; residencial, restaurantes, espacios de trabajo, etc.

Está compuesta por una carcasa de madera alta o baja tapizada disponible en tres bases a elegir con o sin brazos.

El tapizado de la carcasa puede ser soft o tradicional y los brazos, metálicos o tapizados.

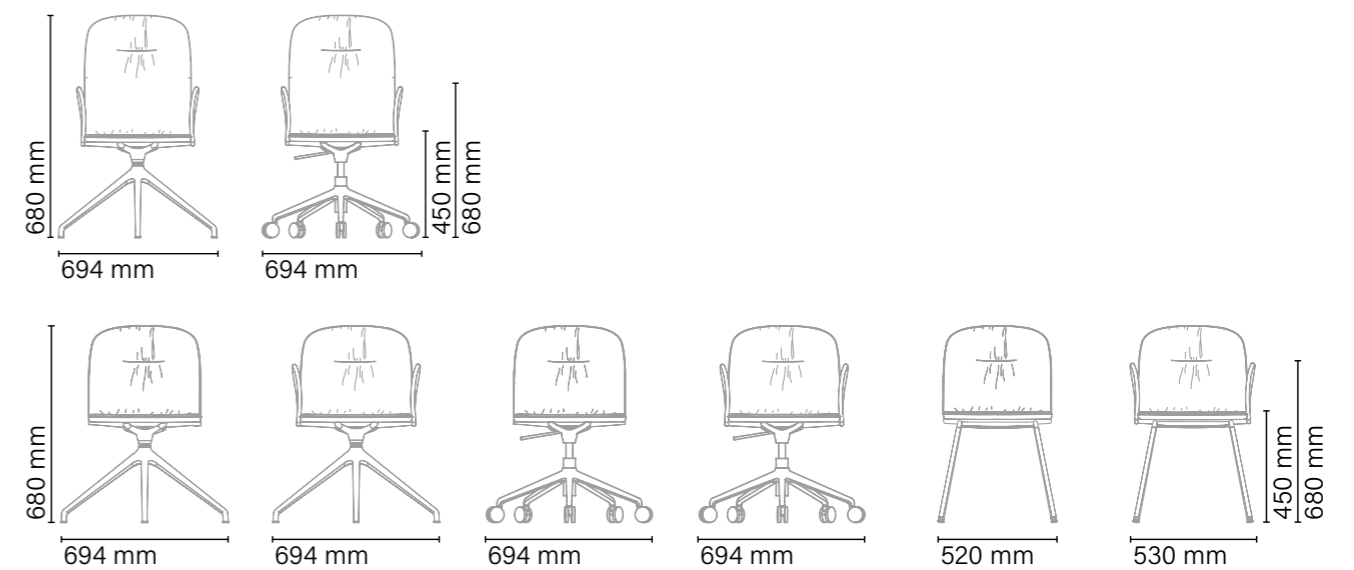



132



133





LOOP collection

Chair / Sillas

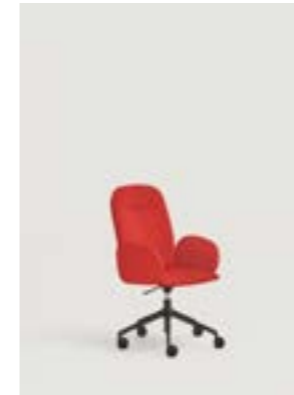

2131DRNT
Upholstered armchair with swivel aluminium base. Fitted with castor wheels / Silla tapizada con base de aluminio con sistema giratorio. Equipada con ruedas

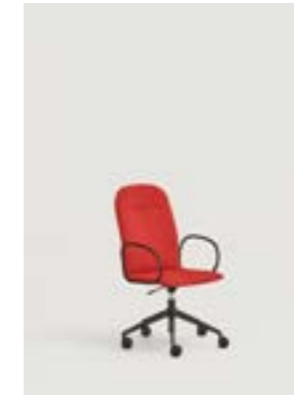

2131DRN
Upholstered armchair with metal arms and swivel aluminium base. Fitted with castor wheels / Silla tapizada con brazos de metal y base de aluminio con sistema giratorio. Equipada con ruedas

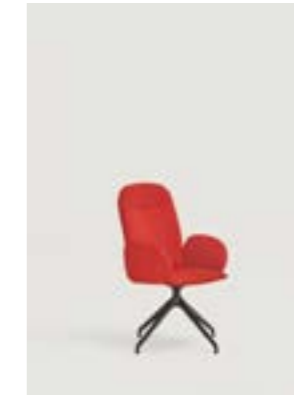

2131DNT
Upholstered armchair with swivel aluminium base / Silla tapizada con base de aluminio con sistema giratorio

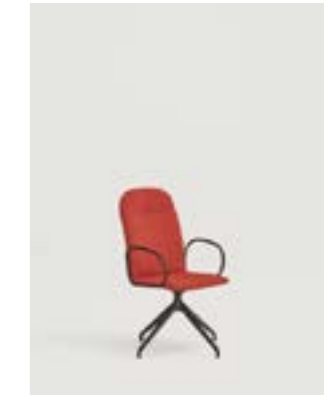

2131DN
Upholstered armchair with metal arms and swivel aluminium base / Silla tapizada con brazos de metal y base de aluminio con sistema giratorio



2130DNT
Upholstered armchair with swivel aluminium base / Silla tapizada con base de aluminio con sistema giratorio



2130DN
Upholstered armchair with metal arms and swivel aluminium base / Silla tapizada con brazos de metal y base de aluminio con sistema giratorio



2130D
Upholstered chair with and swivel aluminium base / Silla tapizada con brazos de metal y base de aluminio con sistema giratorio



2130DRNT
Upholstered armchair with swivel aluminium base. Fitted with castor wheels / Silla tapizada con base de aluminio con sistema giratorio. Equipada con ruedas



2130DRN
Upholstered armchair with metal arms and swivel aluminium base. Fitted with castor wheels / Silla tapizada con brazos de metal y base de aluminio con sistema giratorio. Equipada con ruedas



2130DR
Upholstered chair with metal arms and swivel aluminium base. Fitted with castor wheels / Silla tapizada con brazos de metal y base de aluminio con sistema giratorio. Equipada con ruedas

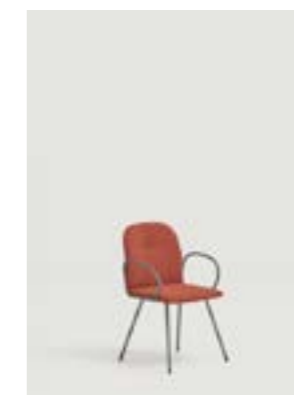

2130VN
Upholstered armchair with metal arms and legs / Silla tapizada con brazos y base de metal



2130VNT
Upholstered armchair with metal legs / Silla tapizada con base de metal



MARIETTA collection

Design by Yonoh

EN Marietta is a collection with a very fresh and customizable design that leaves no one indifferent. Its name comes from Valencian, its translation is Mariquita, referring to the insect from which the design is inspired and emphasizing the local culture. A very funny aesthetic, seen from above, the structure, the seat and the backrest imitate the shape of this little insect, legs, body, head...

The collection consists of a chair, armchair, armchair and stool. It is stackable and has a version for outdoor spaces

ES Marietta es una colección con un diseño muy fresco y personalizable, que no deja indiferente a nadie. Su nombre proviene del Valenciano, su traducción es Mariquita, haciendo referencia al insecto en el que se inspira el diseño y poniendo el énfasis en la cultura local. Una estética muy divertida, visto desde arriba, la estructura, el asiento y el respaldo imitan la forma de este pequeño insecto, patas, cuerpo, cabeza...

La colección se compone de silla, sillón, butaca y taburete. Es apilable y tiene una versión para espacios exteriores

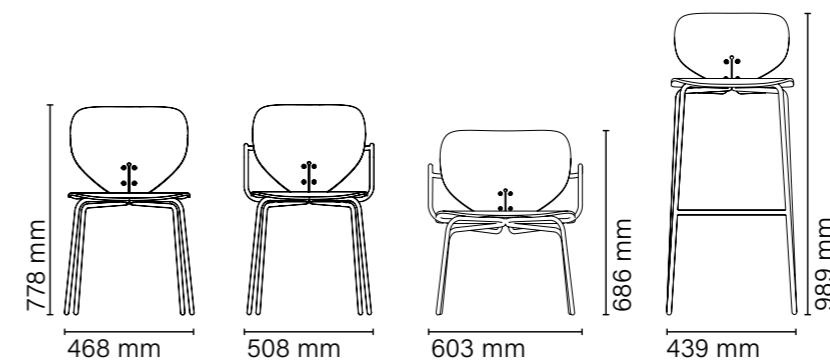



140

141







146

147



MARIETTA collection

Chair / Sillas



2311
Chair with oak wood seat and back. Steel frame / Silla con asiento y respaldo de roble. Estructura de acero.



2311N
Armchair with oak wood seat and back. Steel frame / Silla con brazos con asiento y respaldo de roble. Estructura de acero.



2311U
Upholstered chair with steel frame / Silla tapizada con estructura de acero



2311U-N
Upholstered armchair with steel frame / Silla tapizada con brazos con estructura de acero

Outdoor / Exterior

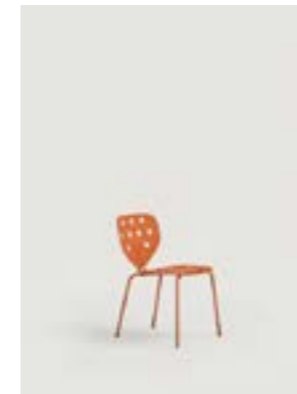

2311INOX
Outdoor chair with aluminium seat and back. Inoxidable steel frame / Silla de exterior con asiento y respaldo de aluminio. Estructura de acero inoxidable



2311INOX-N
Outdoor armchair with aluminium seat and back. Inoxidable steel frame / Silla de exterior con brazos con asiento y respaldo de aluminio. Estructura de acero inoxidable



2315
Lounge chair with oak wood seat and back. Steel frame / Butaca con asiento y respaldo de roble. Estructura de acero.



2315U
Upholstered lounge chair with steel frame / Butaca tapizada con estructura de acero.

Stool / Taburete



2319
Stool with oak wood seat and back. Steel frame / Taburete con asiento y respaldo de roble. Estructura de acero.

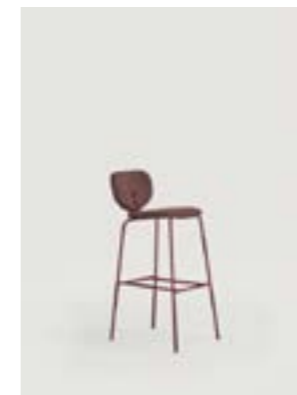

2319U
Upholstered stool with steel frame / Taburete tapizado con estructura de acero.



MARTA collection

Design by Gabriel Teixidó

EN The Marta collection is born from a deep respect for wood. Its subtle design, light appearance and marked natural character make it suitable for very diverse environments.

Manufactured in a traditional way, its design with exposed interlocked joints is articulated around a beech wood structure combined with straps that provide strength and lightness at the same time to each piece.

Chairs, armchairs and low seats where you can caress and smell the wood. A magical experience where the material and the object merge.

ES La colección Marta nace de un profundo respeto por la madera. Su diseño sutil, apariencia liviana y un marcado carácter natural hace que se pueda disponer en ambientes muy diversos.

Fabricada de manera tradicional, su diseño con uniones trabadas vistas, se articula en torno a una estructura de madera de haya combinada con cinchas que aportan solidez y al mismo tiempo, levedad a cada pieza.

Sillas, sillones y butacas bajas donde poder acariciar y oler la madera. Una experiencia mágica en la cual el material y el objeto se funden.

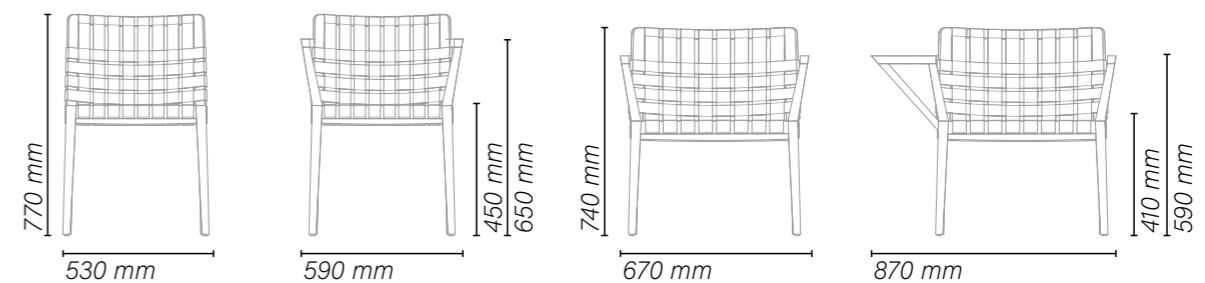







MARTA collection

Chair / Sillas



240CC

Chair with solid beech base and cotton strap seat and back / Silla con estructura de madera de haya y asiento y respaldo con cinchas de algodón



241CC

Armchair with solid beech base and cotton strap seat and back / Sillón con estructura de madera de haya y asiento y respaldo con cinchas de algodón

Lounge / Butaca



243CC

Lounge chair with solid beech base and cotton strap seat and back / Butaca con estructura de madera de haya y asiento y respaldo con cinchas de algodón

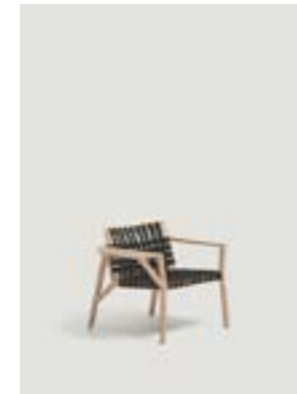

244CC

Lounge chair with table. Solid beech base and cotton strap seat and back / Butaca con mesa. Estructura de madera de haya y asiento y respaldo con cinchas de algodón



MATCH collection

Design by Patrick Norguet

EN This chair was designed to be singular and elegant. Its unique architecture is the result of the perfect match between metal and wood.

The back legs are made in solid oak wood and the front ones in metal. The shape of the seat and the backrest ensure the ergonomics and comfort. Available fully upholstered or only with the seat upholstered.

ES La silla MATCH es una combinación de dos materiales; madera maciza y contrachapado junto con metal.

MATCH muestra una arquitectura sorprendente y singular, basada en un sutil desequilibrio entre madera y metal. Las patas traseras están hechas de madera maciza y las delanteras de metal. La forma del asiento y el respaldo aseguran la ergonomía y el confort.

Destinado a espacios públicos y residenciales. Está disponible en dos versiones: respaldo y asiento tapizados o asiento tapizado y respaldo de madera.

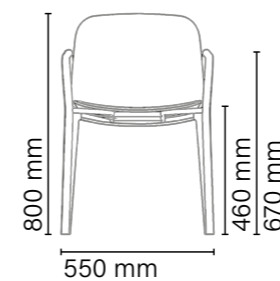

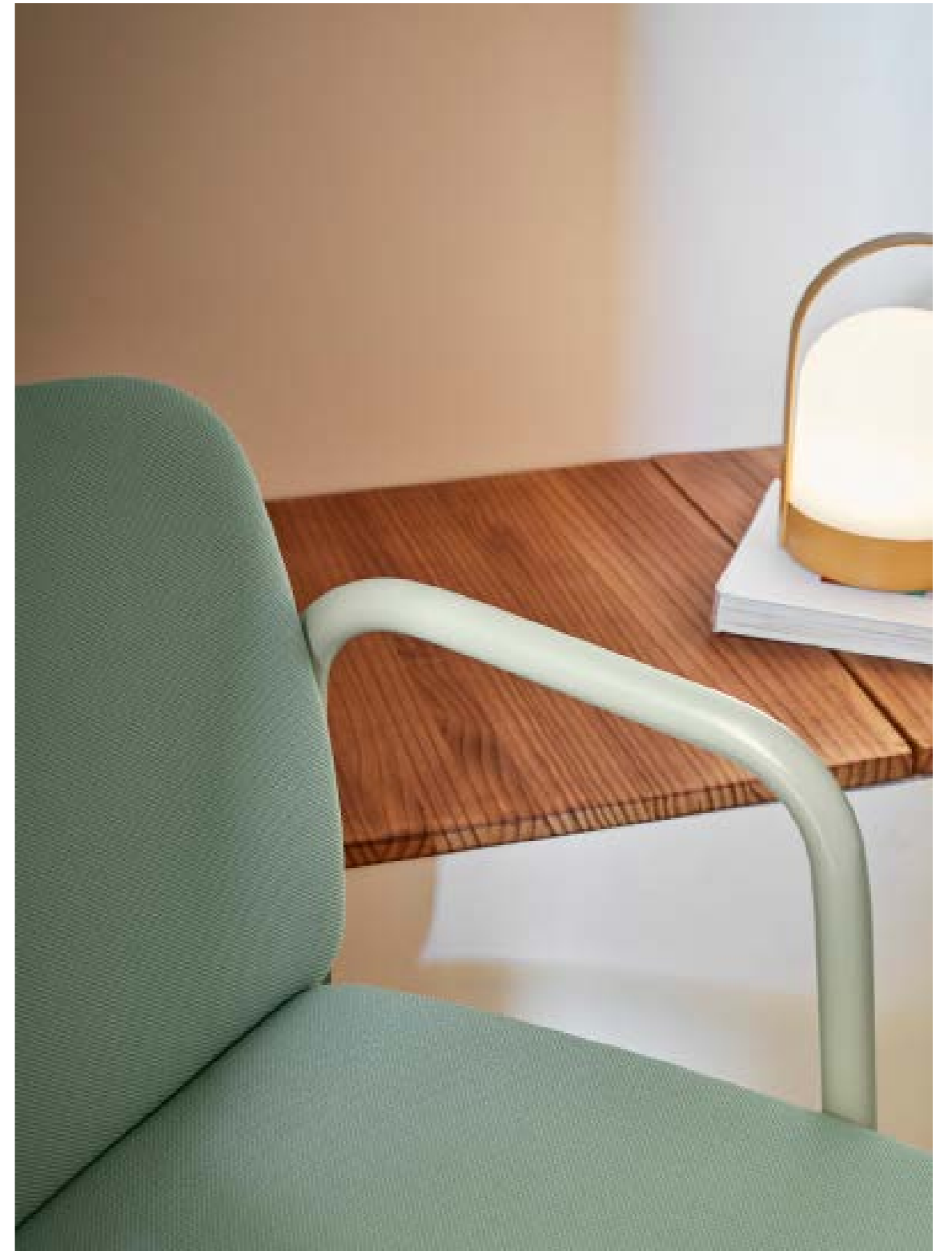





MATCH collection

Chair / Sillas



2021PM

Chair with oak wood shell and back legs. Steel front legs. Upholstered seat / Silla con respaldo y patas trasera de roble. Patas delanteras de acero. Asiento tapizado

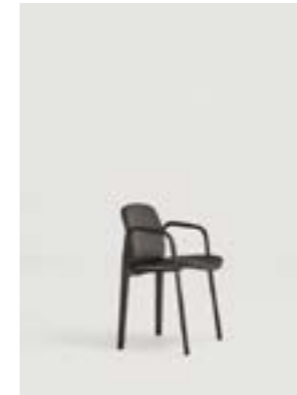

2021PP

Chair with oak wood shell and back legs. Steel front legs. Upholstered seat and back / Silla con respaldo y patas trasera de roble. Patas delanteras de acero. Asiento y respaldo tapizados



MOON collection

Design by Gabriel Teixidó

EN Multifunctionality is one of the characteristics of the MOON collection. A highly resistant polyurethane-coated seat shell, together with the upholstery and the use of various support materials, such as wood (BEECH or OAK) or metal, make the Moon chairs suitable for the home or for other spaces.

Their common denominator: comfort and aesthetics.

ES La multifuncionalidad es una de las características de la colección MOON. Una carcasa de asiento revestida de poliuretano de gran resistencia, junto a la tapicería y el uso de diversos materiales de soporte, como la madera (HAYA o ROBLE) o el metal hacen que las sillas Moon sean apropiadas para el hogar o para otros espacios.

Su denominador común: comodidad y estética.

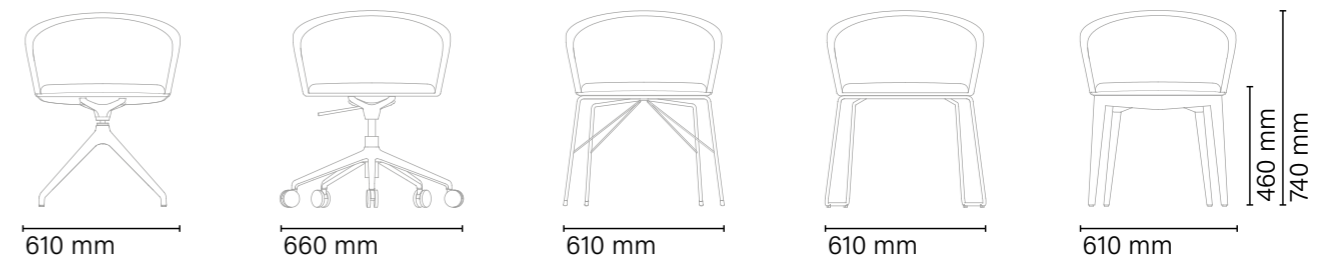









MOON collection

Chair / Sillas



663D
 Upholstered chair with four way swivel aluminium base / Silla tapizada con base de aluminio con sistema giratorio y cuatro radios



663DR
 Upholstered chair with swivel aluminium base. Fitted with castor wheels / Silla tapizada con base de aluminio con sistema giratorio. Equipada con ruedas



663MD4
 Upholstered chair with solid beech or oak wood base / Silla tapizada con base de madera maciza de haya o roble

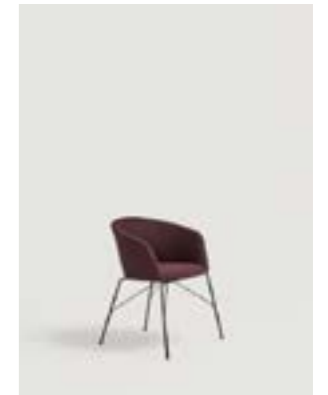

663TNS
 Upholstered chair with solid steel structure / Silla con estructura de varilla de acero con tensor



663PTN
 Upholstered chair with solid steel structure / Silla con estructura de varilla de acero con tensor



176

NARA collection

Design by Mario Ruiz

EN Family of stools that includes 2 lines. A stool with a liftable piston. The basic piece of the leg embraces the column and gives uniqueness to the product. Rod option is also available. Both options are sized to generate a harmonious set between base and seat. It has a markedly symmetrical character, since all its curves are balanced on both axes. The seat has an ergonomic curvature that adapts to the shapes of the body, providing comfort and comfort when sitting.

ES Familia de taburetes que abarca 2 líneas. Un taburete con pistón elevable. La pieza base de la pata abraza la columna y le da singularidad al producto. También está disponible la opción de varilla. Ambas opciones están dimensionadas para que generen un conjunto armonioso entre base y asiento. Tiene un marcado carácter simétrico, ya que todas sus curvas se equilibran en ambos ejes. El asiento tiene curvatura ergonómica que se adapta a las formas del cuerpo aportando comodidad y confort en la sentada.

177

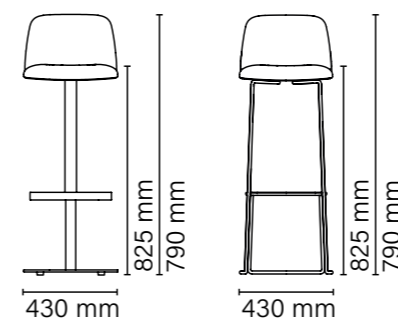



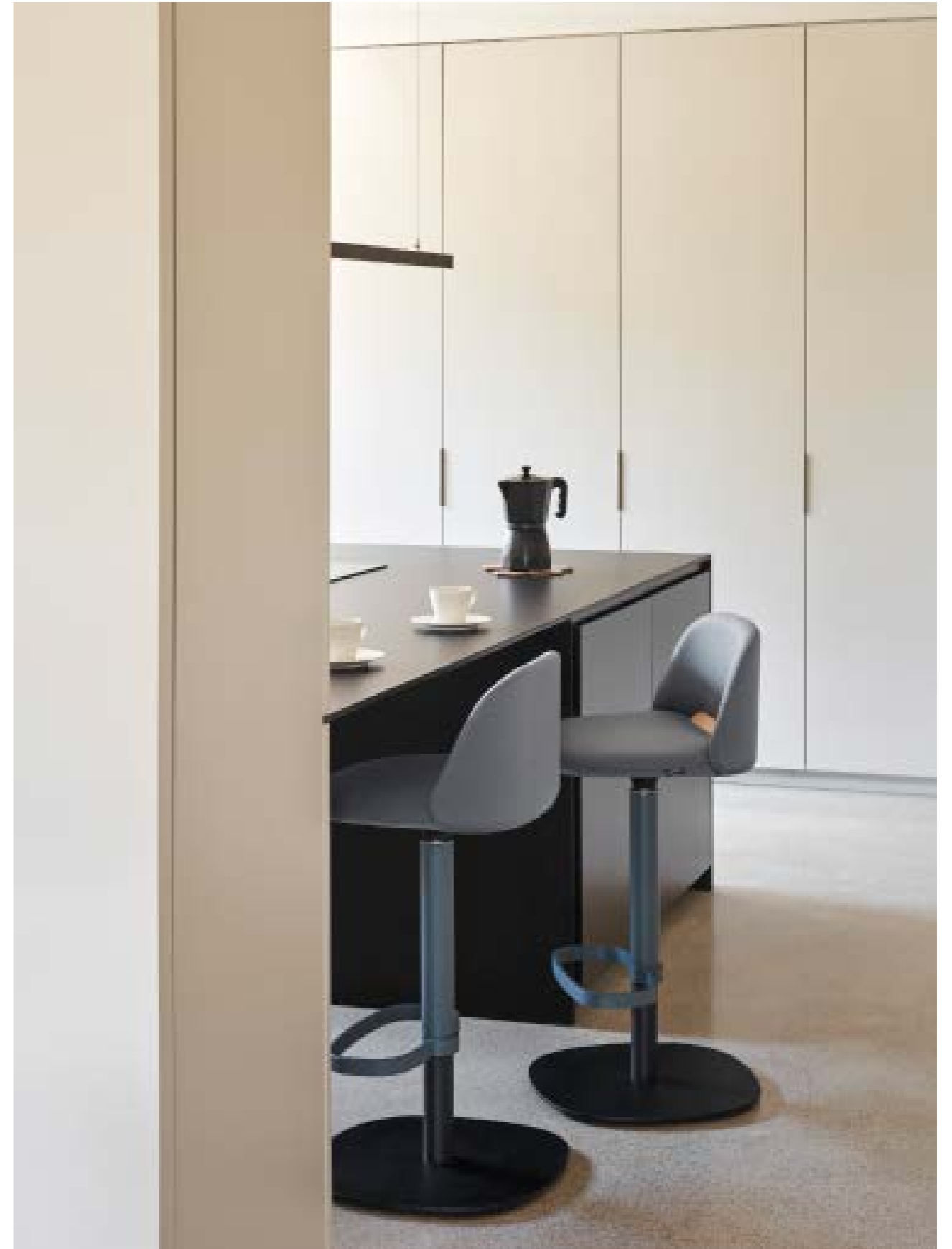



NARA collection

Stool / Taburete



2209P

Upholstered stool with gas swivel base, adjustable height / Taburete tapizado con base de pistón, altura regulable



2209V

Upholstered stool with solid steel structure. Available in 65 cm height / Taburete tapizado con base de varilla. Disponible de 65 cm



NIX collection

Design by Patrick Norguet

EN Nix, an iconic design that combines the work of solid wood and the curved plywood 3D spherical geometry. The result is very comfortable and lends itself to both multiple uses of the house as to the collective spaces.

The principle of assembly draws an elegant and singular architecture.

The Nix collection is growing with the introduction of its stool version NIX STOOL.

A contemporary collection with different finishes and colors whose chair was the winner of the prestigious Red Dot Award, 2019.

ES Nix, un diseño icónico que combina el trabajo de la madera sólida y el contrachapado curvado de geometría esférica 3D. El resultado es una silla muy cómoda que se presta tanto a múltiples usos de la casa como a los espacios colectivos.

El principio del ensamblaje, dibuja una arquitectura elegante y singular.

La colección Nix crece con la introducción de su versión taburete NIX STOOL.

Una colección contemporánea con diferentes acabados y colores cuya silla fue ganadora del prestigioso Red Dot Award, 2019.

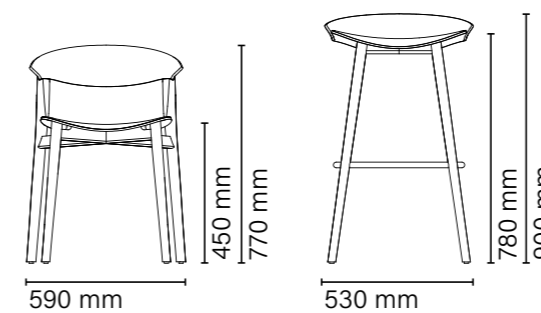



186

187

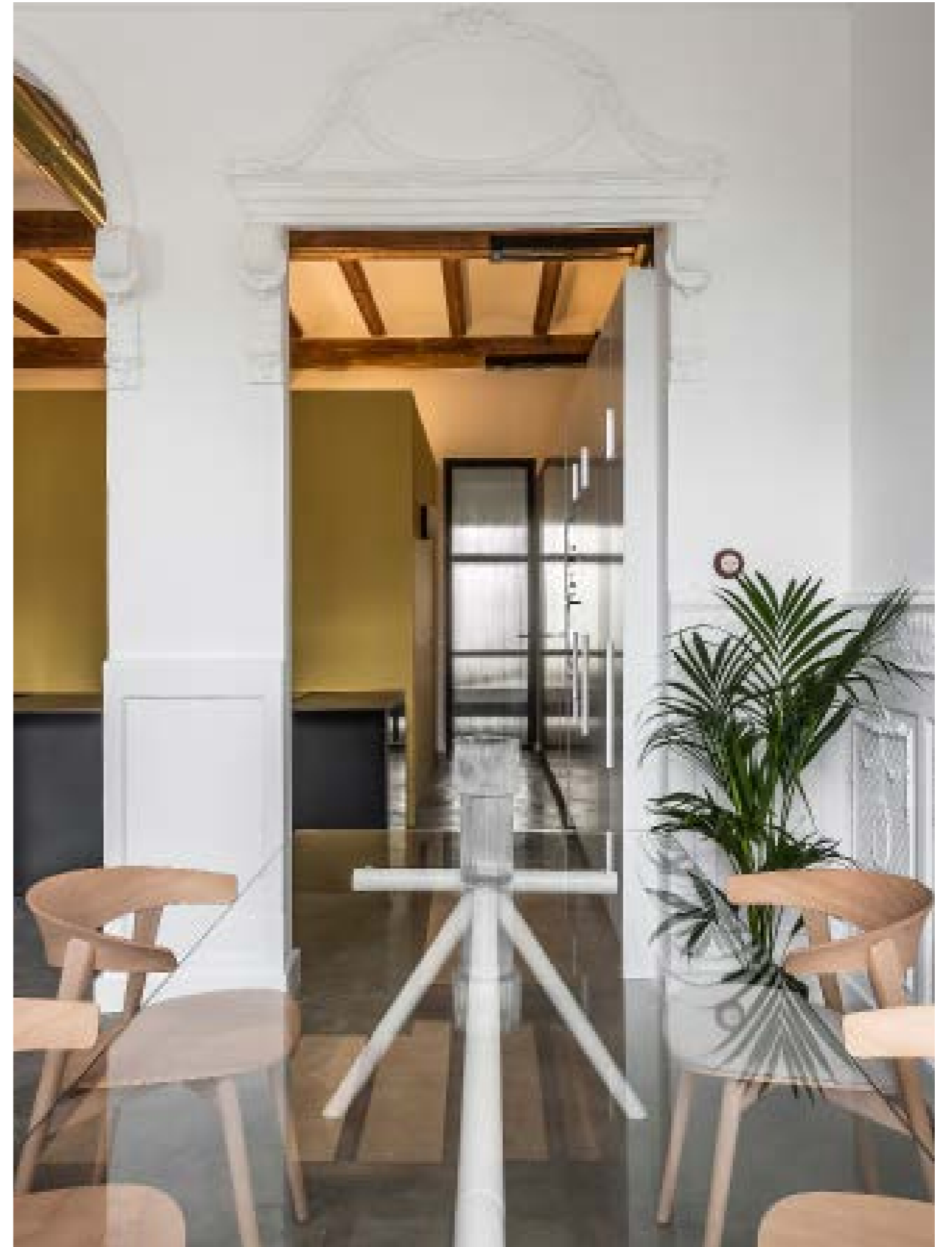





NIX collection

Chair / Sillas

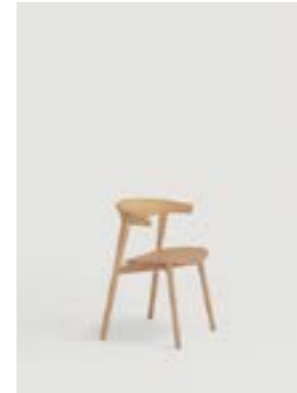

230M

Chair with beech wood base and curved plywood backrest / Silla con estructura de haya y respaldo contrachapado curvado



230P

Upholstered chair with beech wood base and curved plywood backrest / Silla tapizada con estructura de haya y respaldo contrachapado curvado

Stool / Taburete



230M

Stool with beech wood base and curved plywood backrest / Taburete con estructura de haya y respaldo contrachapado curvado



230P

Upholstered stool with beech wood base and curved plywood backrest / Taburete tapizado con estructura de haya y respaldo contrachapado curvado



PANEL collection

Design by Lucy Kurrein

EN Panel is a lounge chair made from sheet steel and tailored wool or leather with exposed edges -a hollow chair rather than a solid one- a light alternative to material-heavy upholstered furniture.

Shape and comfort have been built directly into a seat made of wool or leather through its carefully contoured surface.

The flat section steel frame offers a generous platform for the seat to comfortably rest on - a harmonious union of two materials.

ES Panel es una butaca con estructura de pletina o varilla de acero y revestida de cuero o lana. El interior visto -una butaca hueca en lugar de sólida- supone una alternativa ligera al mobiliario pesadamente sobretapizado. Forma y confort han sido configurados directamente en el asiento a partir de una superficie de cuero o lana cuidadosamente delimitada.

La sección plana de la estructura de acero ofrece una plataforma generosa para el asiento, que descansa confortablemente sobre ella en una armoniosa unión de dos materiales.

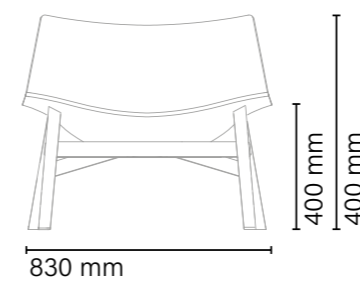







PANEL collection

Lounge / Butaca



517V

Lounge chair with metal structure and premium leather seat / Butaca con estructura metálica de acero y asiento de piel premium



517S

Lounge chair with metal structure and premium waterproof suede leather seat / Butaca con estructura metálica de acero y asiento de ante resistente al agua premium



517F

Lounge chair with metal structure and felt seat / Butaca con estructura metálica de acero y asiento de felpa



POLO collection

Design by Yonoh Studio

EN Polo is a collection of chairs created from flat slats. Its finishes and the way in which its elements are connected allow us to understand the piece in its essence, based on a careful design that gives the result a slight complexity.

The Polo collection is made up of chairs with a beech wood structure, whose seats can be laminated or upholstered. A collection with soul.

ES Polo es una colección de sillas creada a partir de listones planos. Sus acabados y la manera en que están conectados sus elementos permiten comprender la pieza en su esencia, a partir de un diseño cuidado que aporta al resultado una liviana complejidad.

La colección Polo está formada por sillas con estructura de madera de haya, cuyos asientos pueden ser laminados o tapizados. Una colección con alma.

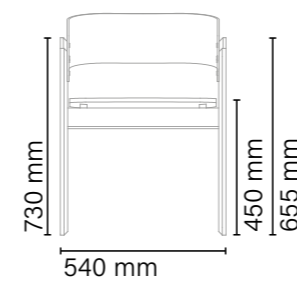





POLO collection

Chair / Sillas



515M

Armchair with beech wood base and beech plywood backrest / Silla con estructura de haya y respaldo de contrachapado de haya



515T

Semi upholstered armchair with beech wood base and beech plywood backrest / Silla semitapizada con estructura de haya y respaldo de contrachapado de haya



STIR collection

Design by Kazuko Okamoto

EN Behind the Stir concept is Okiagari Koboshi, the traditional Japanese paper-mâché lucky doll that sways but always returns to its initial shape thanks to its balanced center of gravity.

Light, enveloping and made of laminated beech, the aesthetics of its lines make the Stir an ethereal and clean chair, with a wooden base that draws perfectly symmetrical semicircles on both the feet and the arms.

A collection of chairs and armchairs with solid oak structure. Upholstered seat and back.

ES Detrás del concepto Stir está Okiagari Koboshi, la tradicional muñeca japonesa de la suerte de papel maché que se balancea pero que siempre regresa a su forma inicial gracias a su equilibrado centro de gravedad.

Ligera, envolvente y hecha de laminado de haya, la estética de sus líneas convierten a Stir en una silla etérea y limpia, con una base de madera que dibuja sendos semicírculos perfectamente simétricos tanto en los pies como en los brazos.

Una colección de sillas y butacas con estructura maciza de roble. Asiento y respaldo tapizados.

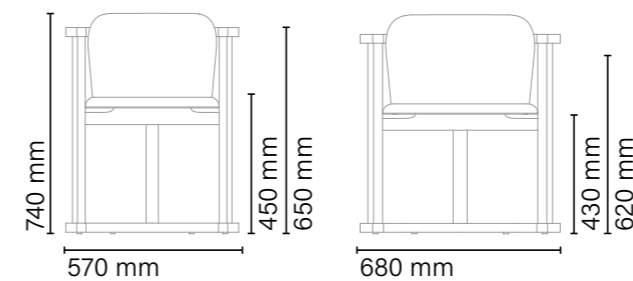





STIR collection

Chair / Sillas



380R

Upholstered armchair with oak base
/ Silla tapizada con base de madera
de roble

Lounge / Butaca



383R

Upholstered lounge chair with oak
base / Butaca tapizada con base de
madera de roble



ULIS collection

Design by Sebastian Herkner

EN The design of the Ulis Lounge adapts to both residential and contract spaces. Sebastian Herkner defines it as his idea of a modern comfort. The soft aesthetic formed to wrap and embrace, guarantees a comfortable and a reclining position at the same time, and make this product space friendly and welcoming. The legs can be made of black metallic tube or a rotating central foot, which combines metal and oak. It is available in two heights.

ES *Ulis Lounge se adapta tanto a espacios residenciales como contract. Sebastian Herkner lo define como su idea de confort moderno. Su estética soft, formada para envolver y abrazar, y al mismo tiempo garantizar una posición cómoda y reclinada hacen que este producto convierta los espacios en amables y acogedores. Las patas pueden ser de tubo metálico negro o un pie central giratorio, que combina metal y el roble. Disponible en dos alturas.*

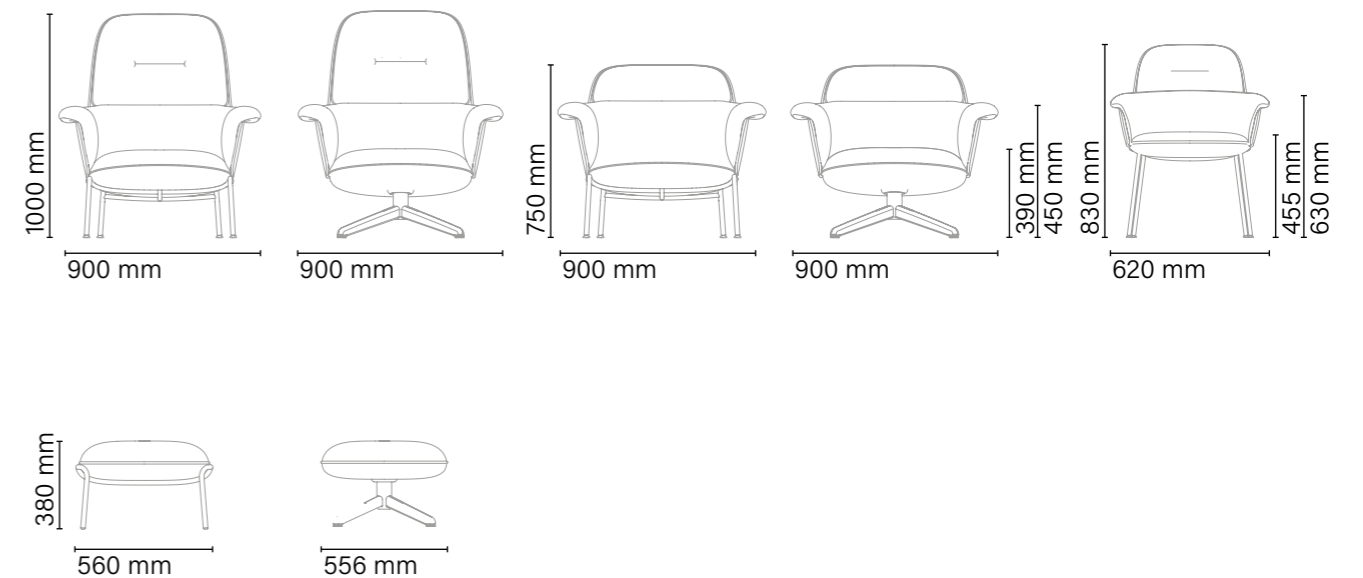









222

223





ULIS collection

Chair / Silla



2155
Upholstered armchair with metal legs / Silla tapizada con patas metálicas



2155R
Upholstered armchair with oak wood frame and metal legs / Silla tapizada con carcasa de madera y patas metálicas

Lounge / Butaca



2152
Upholstered lounge chair with low case and metal base / Butaca tapizada con carcasa baja y base de metal



2151
Upholstered lounge chair with high case and metal base / Butaca tapizada con carcasa alta y base de metal



2152G
Upholstered lounge chair with low case and wood base / Butaca tapizada con carcasa baja y base de madera



2151G
Upholstered lounge chair with high case and wood base / Butaca tapizada con carcasa alta y base de madera

Footrest / Reposapiés



2158
Upholstered footrest with metal legs / Reposapiés tapizado con patas metálicas



2158G
Upholstered footrest with oak wood legs / Reposapiés tapizado con patas de madera de roble



WEDGE collection

Design by Marcel Sigel

EN Solid wooden structure with seat and chair back in oak plywood, The restback is available in oak wood or upholstered.

The chair features a forward facing cantilevered seat. Although highly visual, its origins have little to do with aesthetics, rather it exists purely as a result of function and rational in the chairs construction.

The starting point for the design was a reflection on the constructive components that define all chairs; a seat, a backrest, and legs. In this case the three elements are visually separated, connected by a single unifying triangle/ wedge. Each side of the triangle serves to fix in place one element creating the structure.

ES Wedge es una silla con patas macizas de roble y asiento tapizado. El respaldo está disponible en madera o tapizado.

La silla cuenta con un asiento en voladizo orientado hacia adelante. Aunque resulta muy visual, sus orígenes tienen poco que ver con esta estética, más bien este diseño es el resultado de la función y la racionalidad en la construcción de sillas.

El punto de partida del diseño fue una reflexión sobre los componentes constructivos que definen a todas las sillas; un asiento, un respaldo y las piernas. En este caso, los tres elementos están visualmente separados, conectados por un solo triángulo/cuña unificadora. Cada lado del triángulo sirve para fijar en su lugar un elemento que crea la estructura.

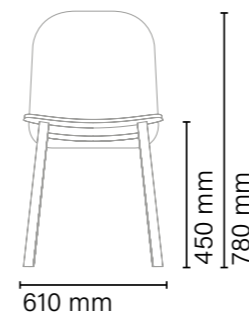



WEDGE collection

Chair / Sillas



360TM

Upholstered chair with base and backrest in oak or beech wood. / Silla tapizada con base y respaldo de madera de roble o haya

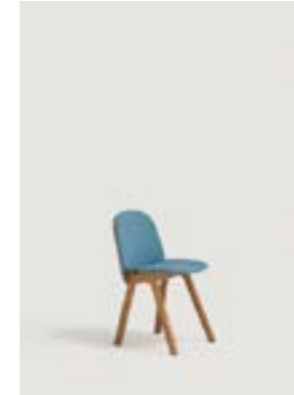

360TT

Fully upholstered with base and backrest in oak or beech wood. / Silla tapizada con base y respaldo de madera de roble o haya

SOFAS AND BENCHES /
SOFÁS Y BANCOS



ATOLL collection

Design by Fiorenzo Dorigo

EN The Atoll collection is a pouf system conceived as a set of independent islands. Its volumes, based on basic geometries, (Triangle, square, pentagon) vary their shape according to the size of the pouf. The finish on their sewings give each piece a unique design.

Atoll is available in four sizes with one, four or five seats with a wide range of fabrics and leather finishings.

Its internal structure of polyurethane foam with a wood base makes the product light and easy to move around.

ES La colección Atoll es un sistema de poufs con volúmenes basados en geometrías básicas (Triangular, cuadrada y pentagonal), varían su forma según el tamaño de pouf. Sorprendentemente cómodos, idoneos para espacios comunes, zonas de trabajo, hoteles, hogar y retail.

El juego de sus formas se refleja en el detalle de las costuras, dándole una personalidad única y especial a cada pieza.

Atoll está disponible en cuatro tamaños de una, cuatro y cinco plazas, con una gama amplia de tapizados en tela o en piel.

Su estructura interior de espuma de poliuretano con base de madera hace que las piezas sean ligeras y fáciles de mover.

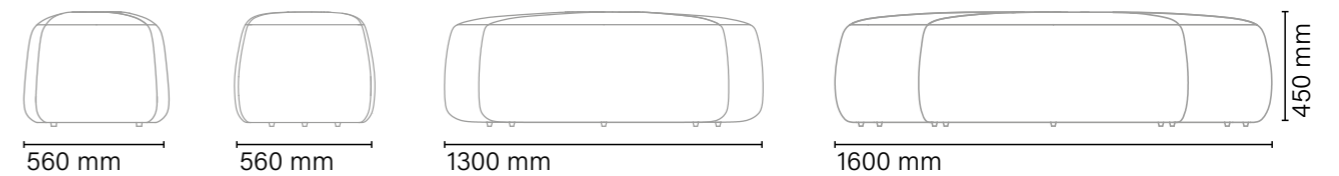





ATOLL collection

Poufs / Poufs



2011T

One seat pouf with polyurethane foam structure. Triangular shape / Pouf de una plaza con estructura de espuma de poliuretano. Forma triangular



2011C

One seat pouf with polyurethane foam structure. Square shape / Pouf de una plaza con estructura de espuma de poliuretano. Forma cuadrada



2013

Four seat pouf with polyurethane foam structure / Pouf de cuatro plazas con estructura de espuma de poliuretano



2018

Five seat pouf with polyurethane foam structure / Pouf de cinco plazas con estructura de espuma de poliuretano



BOLERO collection

Design by Claesson Koivisto Rune

EN Bolero is a sofa with generous and sinuous shapes that invites you to be welcomed and embraced. The foam seat specially chosen for a comfortable sitting. The backrest is also covered with foams. The entire product is supported on a wooden base with straight lines, which contrast with the sinuosity of the product. Play between the curve, the straight line and the tangency. It is available in several versions: single-seater, two-seater and bench. The name comes from the inspiration of the designers "We think that the arm and back of the sofa resembles a collar, or more specifically a fur collar from the 1920s"

ES Bolero es un sofá de formas generosas y sinuosas que invita a la acogida y al abrazo. El asiento de espuma especialmente elegida para una sentada cómoda. El respaldo también está cubierto con espumas. Todo el producto va sustentado sobre una base de madera de líneas rectas, que contrastan con la sinuosidad del producto. Juega entre la curva, la recta y la tangencia. Está disponible en varias versiones: monoplaza, biplaza y bancada. El nombre viene de la inspiración de los diseñadores "Creemos que el brazo y el respaldo del sofá se asemejan a un cuello, o más específicamente a un cuello de piel de la década de 1920"

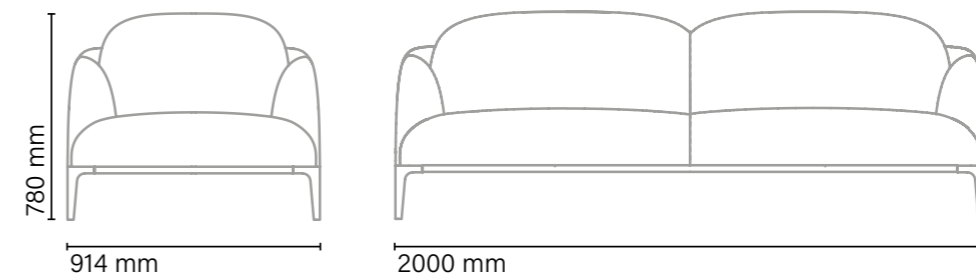





244

245



BOLERO collection

Sofas / Sofás

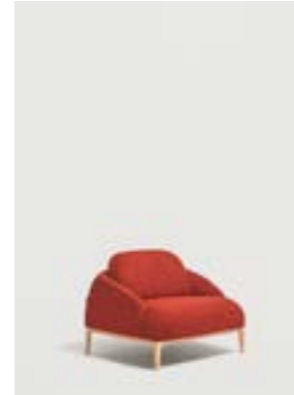

2211
Upholstered one seat sofa with
beech wood base / Sofá de una
plaza tapizado con base de madera
de haya



2212
Upholstered sofa with beech wood
base / Sofá tapizado con base de
madera de haya



BRIDGE collection

Design by Vicente Soto

EN Comfortable and timeless. The tubular steel structure embraces the upholstered seat creating a perfect harmony. With organic shapes and generous extra foam, this collection exudes comfort and visual appeal. Its seductive lines allow it to adapt to countless spaces: common areas, rooms, waiting areas, retail.

Steel base Ø22 mm in powder-coated or chromed finishes and upholstered seat and back.

ES Cómoda y atemporal. La estructura de acero tubular abraza el asiento tapizado creando una armonía perfecta. De formas orgánicas y un generoso extra de espuma, esta colección desprende comodidad y atractivo visual. Sus líneas seductoras le permiten adaptarse a infinidad de espacios: zonas comunes, habitaciones, zonas de espera, retail.

Base tubular de acero de diámetro 22 mm recubierta de pintura en polvo o cromada. Asiento y respaldo totalmente tapizados.

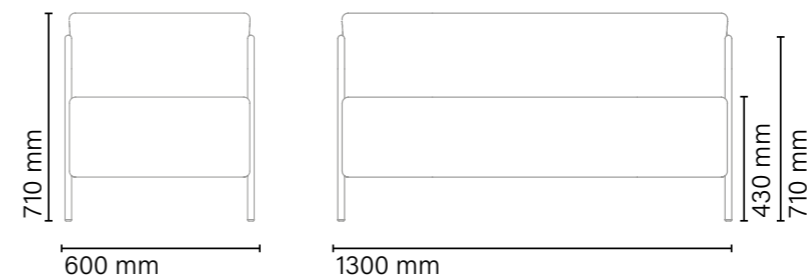



250

251



252



253



BRIDGE collection

Sofas / Sofás



817
Upholstered lounge chair, iron frame
/ Sillón tapizado, estructura acero



817S
Upholstered sofa, iron frame / Sofá
tapizado, estructura acero



DROPLETS collection

Design by Claesson Koivisto Rune

EN Collection of benches and side tables with a light and elegant aesthetic. A minimalist design but with a presence that impacts the environment. The designers, the Claesson Koivisto Rune, were inspired by the shapes that droplets of water make when they land on a surface. The different models allow endless combinations that make this collection a set perfectly adaptable to common spaces, retail and hotels.

The main structure of the collection is birch plywood upholstered with two different foams to make it comfortable. The legs are 16 mm steel tube.

DROPLETS LOW TABLES PAGE 322

ES Colección de bancos y mesas auxiliares de estética libiana y elegante. Un diseño minimalista pero con una presencia que impacta en el entorno. Los diseñadores, los Claesson Koivisto Rune, se inspiraron en las formas que las gotas de agua componen al posarse sobre una superficie. Los distintos modelos permiten infinitas combinaciones que hacen de esta colección un conjunto perfectamente adaptable a espacios comunes, retail y hoteles.

La estructura consta de un tablero de 15 mm de contrachapado de abedul tapizado con dos espumas de diferentes densidades para darle una mayor comodidad. Pies de tubo de hierro reforzado de 16 milímetros.

MESAS DROPLETS PÁGINA 322

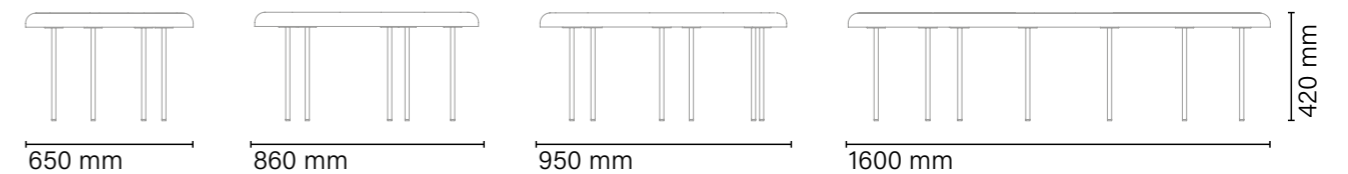



258

259





DROPLETS collection

Bench / Banco



182
Bench upholstered seat with steel
legs / Banco asiento tapizado con
patas metálicas



183
Bench upholstered seat with steel
legs / Banco asiento tapizado con
patas metálicas



184
Bench upholstered seat with steel
legs / Banco asiento tapizado con
patas metálicas



186
Bench upholstered seat with steel
legs / Banco asiento tapizado con
patas metálicas



INSULA collection

Design by Patrick Norguet

EN This collection is a system of seats and tables that offer a simple and elegant solution for decorating common spaces. The designer, Patrick Norguet, wants the combination of the pieces in this collection to evoke natural landscapes. Much more than a set, Ínsula is first of all a system: it is made up of a basic structure on which the seats, backrests and accessories are fixed. This project is conceived as a set of simple construction and combinations, without forgetting the main function, the comfort of its use.

Modular sofa set based of a combination of 2 lengths of seat (short and long) and 3 sizes of back (A, B & C), with different shapes and sizes of tables in different material. Metal legs with epoxy finishing.

INSULA LOW TABLES PAGE 342

ES Esta colección es un sistema de asientos y mesas que ofrecen una solución sencilla y elegante para vestir espacios comunes. El diseñador, Patrick Norguet, busca que con la combinación de las piezas de esta colección se evoque a los paisajes naturales. Mucho más que un conjunto, Ínsula es antes que nada, un sistema: se compone de una estructura básica sobre la cual se fijan los asientos, los respaldos y los accesorios. Se concibe este proyecto como un conjunto de construcción simple y de combinaciones, sin olvidar la función principal, la comodidad de su uso.

Sistema de sofá modular compuesto de 2 asientos (corto y largo) y 3 respaldos (A, B y C) combinados y unidos entre si con un sobre de mesa de diferentes formas y materiales, permiten a Insula adaptarse a los más variados espacios. Pies metálicos recubiertos de pintura en polvo.

MESITAS INSULA PÁGINA 342

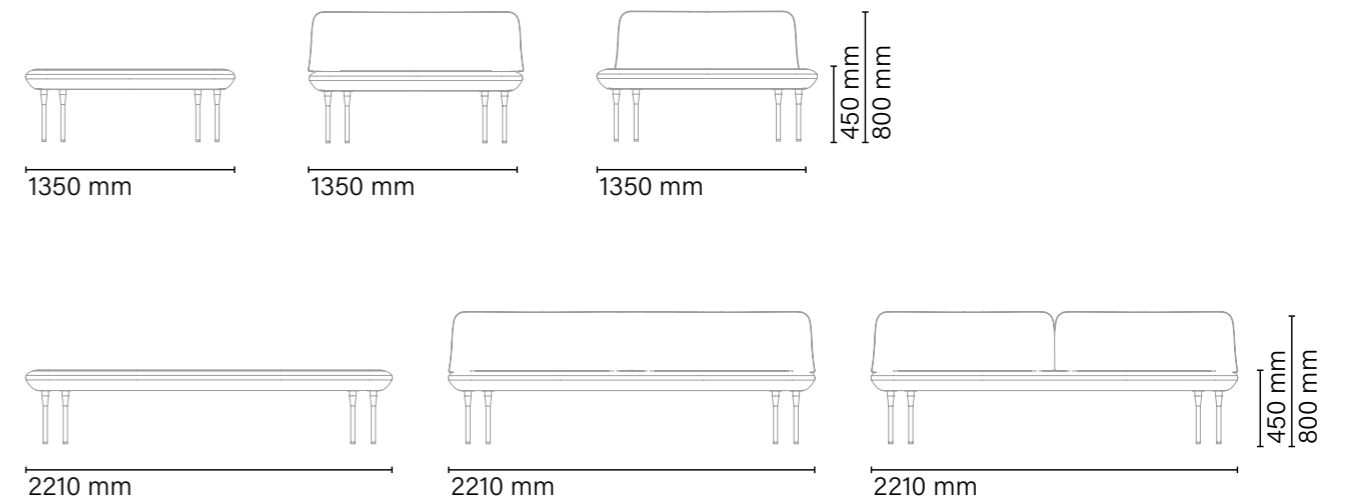



266

267

Sofas & Benches /
Sofás y Bancos

capdell

capdell

Sofas & Benches /
Sofás y Bancos





INSULA collection

Sofas / Sofás

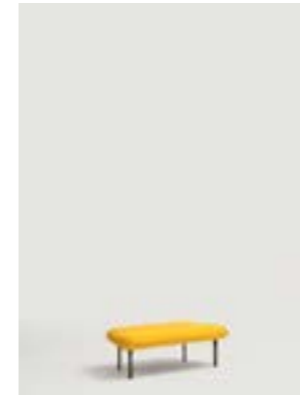

450
Module of short upholstered seat without backrest and metal legs / Módulo asiento largo tapizado sin respaldo y patas metálicas

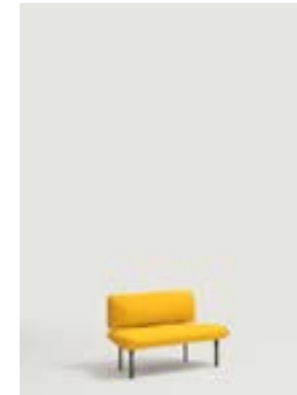

450A
Module of short upholstered seat with one small backrest (A) and metal legs / Módulo asiento corto tapizado con un respaldo pequeño (A) y patas metálicas

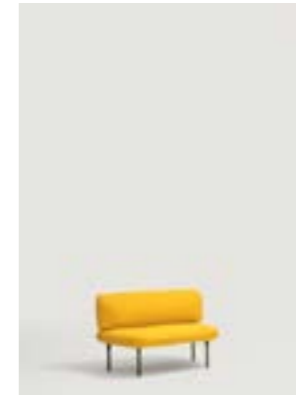

450B
Module of short upholstered seat with one big backrest (B) and metal legs / Módulo asiento corto tapizado con un respaldo mediano (B) y patas metálicas



451
Module of long upholstered seat without backrest and metal legs / Módulo asiento largo tapizado sin respaldo y patas metálicas

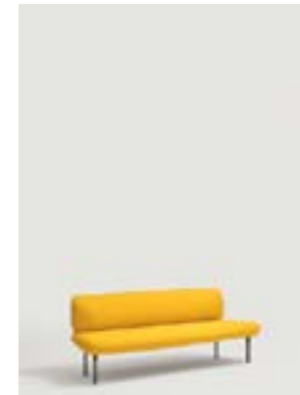

451C
Module of long upholstered seat with one big backrest (C) and metal legs / Módulo asiento largo tapizado con un respaldo grande (C) y patas metálicas

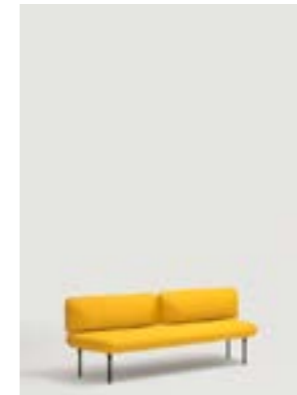

451AA
Module of long upholstered seat with two small backrests (AA) and metal legs / Módulo asiento largo tapizado con dos respaldos pequeños (AA) y patas metálicas

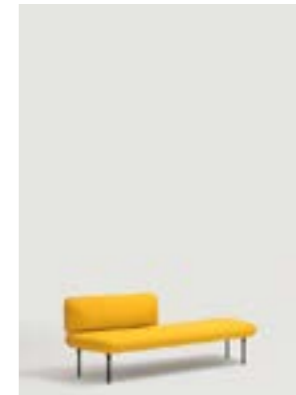

451AX
Module of long upholstered seat with one small backrest (A) and metal legs / Módulo asiento largo tapizado con un respaldo pequeño (A) y metálicas



451XA
Module of long upholstered seat with one small backrest (A) and metal legs / Módulo asiento largo tapizado con un respaldo pequeño (A) y metálicas



452
Table connexion / Conexión mesa



Sofas & Benches /
Sofás y Bancos

NODAL collection

Design by Luca Nichetto

EN Responding to the concept of personalized combination, Nodal is a system of sofas whose modularity allows multiple configurations.

Starting from a platform with 1, 2 or 3 seats, to which you attach rectangular modules that function as armrests and backrests, you can create any combination, from an independent sofa

to benches and more elaborated combinations. The modular platform of the seat allows for the integrated addition of functional extensions, such as tables or joints to create different linear compositions.

The Nodal collection offers interior designers and architects the possibility of making almost any assembly, almost like a Lego set.

ES Respondiendo al concepto de la combinación personalizada, Nodal es un sistema de sofás cuya modularidad permite múltiples configuraciones.

Partiendo de una plataforma de 1, 2 o 3 asientos, a la cual le acoplas módulos rectangulares que hacen función de brazo y de respaldo puedes crear cualquier combinación, desde un sofá independiente hasta bancos y combinaciones más elaboradas. La plataforma modular del asiento permite agregar de forma integrada, extensiones funcionales, como mesas, o uniones para crear diferentes composiciones lineales.

La colección Nodal ofrece a diseñadores de interiores y arquitectos la posibilidad de realizar casi cualquier montaje, casi como con un juego de lego.

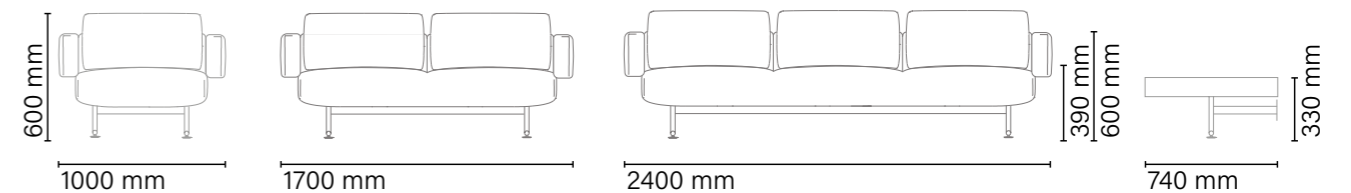

Sofas & Benches /
Sofás y Bancos



274

275





278

279



NODAL collection

Sofas / Sofás



2141

One seat sofa with black powder-coated metal base. Adjustable metal glides/ *Sofá una plaza con base metálica recubierta de epoxi negro. Tacos metálicos regulables*



2142

Two seat sofa with black powder-coated metal base. Adjustable metal glides/ *Sofá dos plazas con base metálica recubierta de epoxi negro. Tacos metálicos regulables*

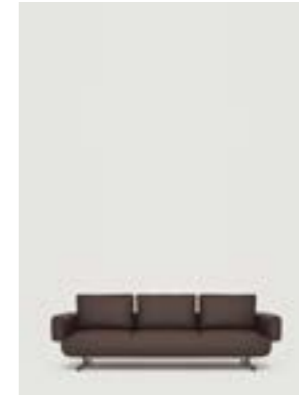

2143

Three seat sofa with black powder-coated metal base. Adjustable metal glides/ *Sofá tres plazas con base metálica recubierta de epoxi negro. Tacos metálicos regulables*



2140T

Table for all typologies in oak or walnut wood / *Mesa incorporable a todos los modelos en madera de roble o nogal*



PLUM collection

Design by Claesson Koivisto Rune

EN A Plum collection with elegant proportions, it has been carefully designed to be soft and welcoming. As if it were an embrace, the outline and rounded shapes that give the collection its character are not strictly mathematical, but a combination of curves that interlace and invite you to sit on them.

A collection of sofas that works in any space, whether in a hotel lobby or in the living room of a home; that is why a lot of attention has been devoted to sculpting the volume of each piece from all angles, even from the rear.

ES Una colección Plum de proporciones elegantes, ha sido cuidadosamente diseñada para resultar suave y acogedora. Como si se tratara de un abrazo, el perfil y las formas redondeadas que dan a la colección su carácter no son estrictamente matemáticas, sino una combinación de curvas que se enlazan e invitan a sentarse en ellos.

Colección de sofás que funciona en cualquier espacio, ya sea en el lobby de un hotel o en el salón de una vivienda; por eso se ha dedicado mucha atención a esculpir los volúmenes de cada pieza desde todos los ángulos, incluso desde la parte trasera.

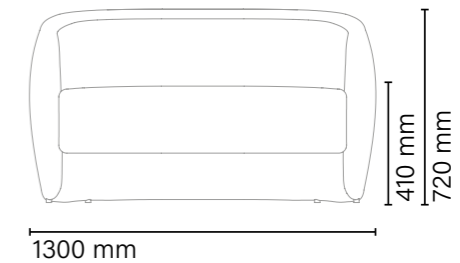
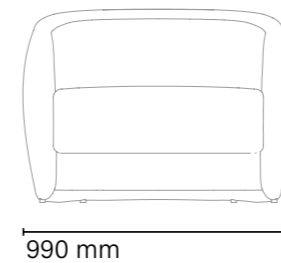
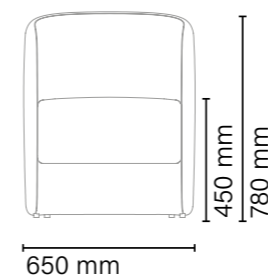





Sofas & Benches /
Sofás y Bancos

capdell



capdell

Sofas & Benches /
Sofás y Bancos



PLUM collection

Sofas / Sofás



560
Upholstered armchair. Optional
wheels (560R) / Butaca tapizada.
Ruedas opcionales (560R)



565
Big size upholstered lounge chair /
Butaca tapizada tamaño grande



560S
Upholstered sofa / Sofá tapizado



VISION collection

Design by Fiorenzo Dorigo

EN Vision, collection of seats for waiting, relaxing or working. The shape of the backrests -high or low- creates reserved areas for intimate and quiet moments or for discreet business meetings. The structures on both sides give Vision personality and a very special look. The seat of the Vision is removable.

ES Vision, colección de asientos para esperar, relajarse o trabajar. La forma de los respaldos -altos o bajos- crea áreas reservadas para momentos íntimos y tranquilos o para discretos encuentros de negocios. Las estructuras en ambos laterales dan a Vision personalidad y un aspecto muy especial. El asiento del Vision es desenfundable.

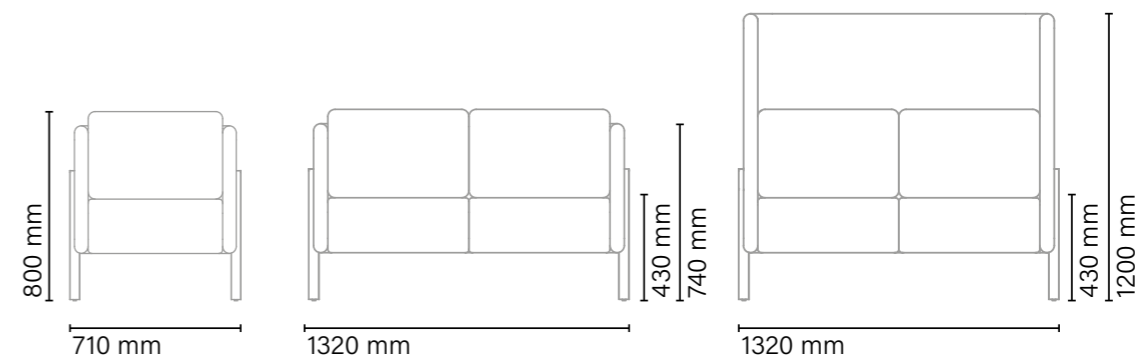





VISION collection

Sofas / Sofás



570
Upholstered one seat sofa with
beech wood legs/ *Sofá tapizado
de una plaza con pies de madera
de haya*



570S
Upholstered two seat sofa with
beech wood legs/ *Sofá tapizado
de dos plazas con pies de madera
de haya*



570SA
Upholstered two seat sofa with
beech wood legs. High back/ *Sofá
tapizado de dos plazas con pies de
madera de haya. Respaldo alto*

TABLES /
MESAS



ABLE collection

Design by Claesson Koivisto Rune

EN Able is a collection of tables focused on the material, the wood, with a 'natural' finish as if it had just come from the sawmill, contrasted with the structural bars of the frame and visible details that make up the table's skeleton. The proportions play with the stylistic dichotomy between the solid structure of the slightly slanted legs in solid oak and the elegant and table top that renders the whole streamlined and aerodynamic. Various types and sizes are available.

ES Able es una colección de mesas centrada en el material, la madera, con un acabado "natural" como si acabara de salir del aserradero, contrastando con las barras estructurales y los detalles visibles que conforman el esqueleto de la mesa. Las proporciones juegan con la dicotomía estilística entre la sólida estructura de las patas ligeramente inclinadas de roble macizo y el elegante tablero que hace que el conjunto sea elegante y aerodinámico. Hay diferentes tipos y tamaños disponibles.

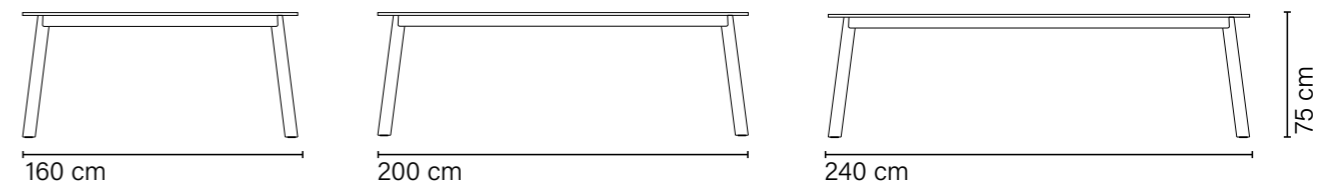



300



301



ABLE collection

Table / Mesa



TA

Table with steel structure, solid oak legs and oak veneer top / Mesa con estructura de metal, patas de madera maciza de roble y tapa chapada en madera de roble



ARO collection

Design by Carlos Tíscar

EN Aro is a collection with a timeless, comfortable and enveloping design, which reinterprets the round seat typology, referring to traditional cabinetmaking. //With the common denominator of the circle through which various elements such as chairs, armchairs, stools and side tables are achieved.

The warmth of the wood and its upholstered versions make it a perfect option for a wide variety of spaces in hotels, restaurants, work environments, home.

Made with PEFC sustainable wood, it can be recycled promoting the circular economy.

ES Aro es una colección con un diseño atemporal, cómoda y envolvente, que reinterpreta la tipología de asiento redondo, evocando a la ebanistería tradicional.

Con el círculo como denominador común de la colección se consiguen diversos elementos como sillas, butacas, taburetes y mesitas auxiliares.

La calidez de la madera y sus versiones tapizadas, la convierten en una opción perfecta para gran variedad de espacios en hoteles, restaurantes, entornos de trabajo, hogar.

Fabricada con maderas sostenibles PEFC, esta puede ser reciclada fomentando la economía circular.

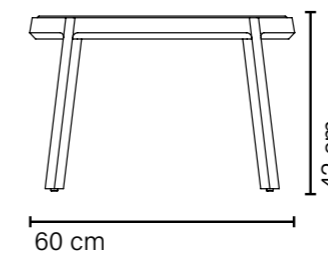
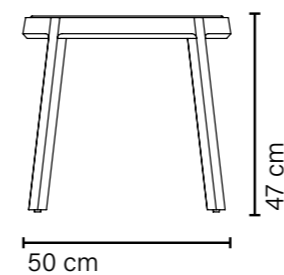

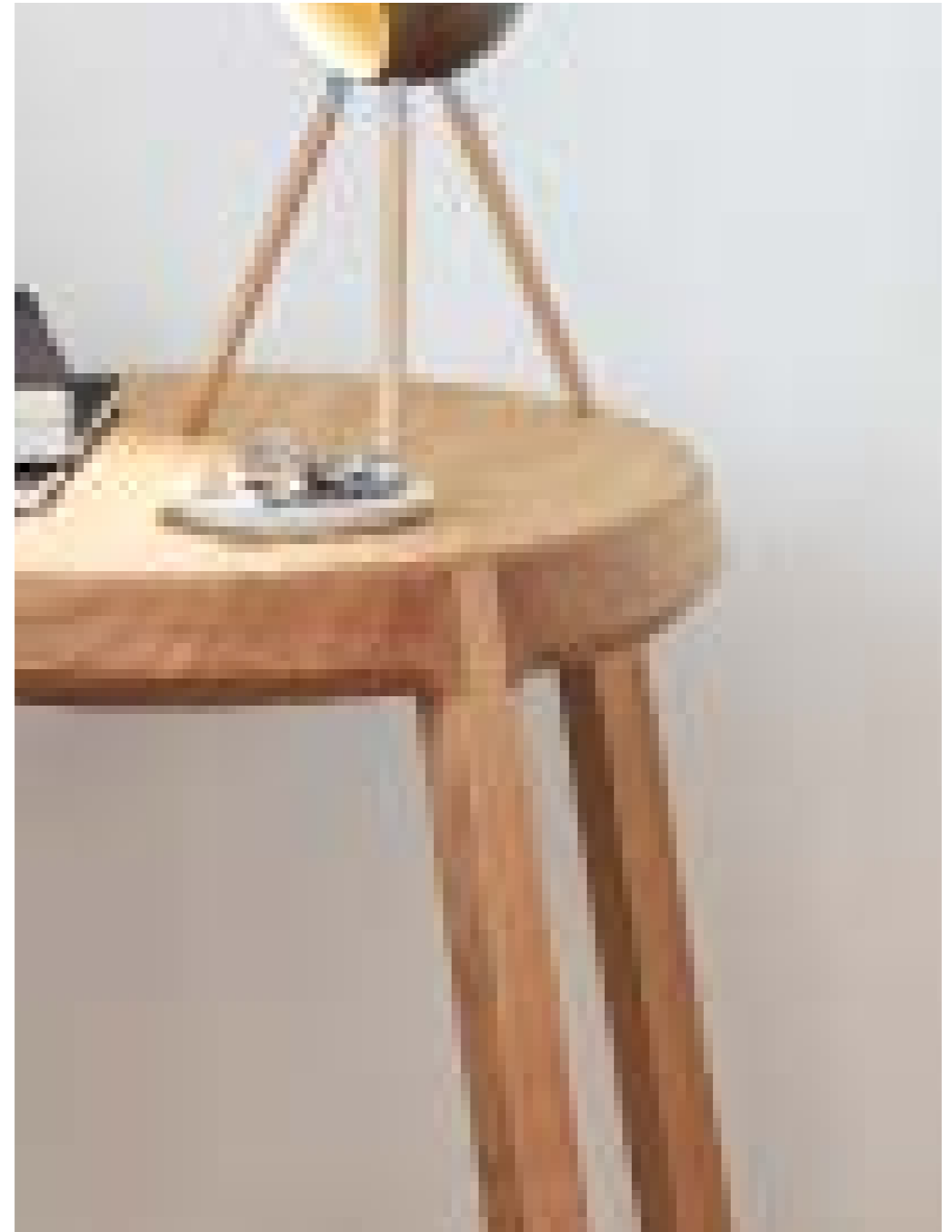



ARO collection

Table / Mesa



690M

Coffee table with base and top of oak or beech veneer top./ Mesa de café patas y tapa de madera de roble o haya



694M

Coffee table with base and top of oak or beech veneer top./ Mesa de café patas y tapa de madera de roble o haya



ATRIA Collection

Design by Gabriel Teixidó

EN Atria is a collection of seats that includes chairs, armchairs, lounge chairs and a table. Its soft and light shapes emanate the warmth of the materials: solid oak and premium leather.

Atria table comes with a solid oak wood structure. The top with an oak veneer finish. Available in 4 sizes: 200 x 100, 240 x 100, and 300 x 100 cm.

Its name refers to the atrium of Roman houses, around which the social life of the house revolved. It also means the brightest star.

ES Atria es una colección de asientos, compuesta por silla, silla con brazos, butaca y mesa. Sus formas suaves y ligeras emanan la calidez de los materiales: el roble macizo y cuero.

La mesa Atria está hecha con estructura de madera de Roble maciza. La tapa con acabado chapado en roble. Disponible en 4 tamaños: 200 x 100, 240 x 100 y 300 x 100 cm.

Su nombre hace referencia al atrio de las viviendas romanas, en torno al cual giraba la vida social de la casa. También significa la estrella que más brilla.

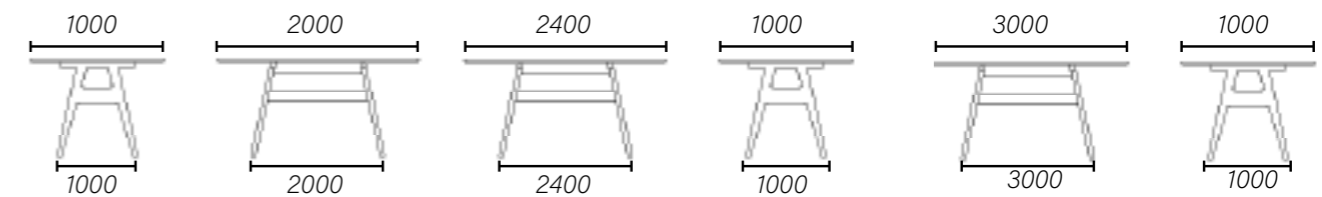





ATRIA collection

Table / Mesa



2322-1

Oak table with oak plywood top.
Mesa de roble on tapa chapada en roble



BASIC TABLES collection

Design by Capdell

EN Basic is a collection of tables with steel base covered with epoxy paint. The base and top are available in round or square shape. Its simple and bold design and its customization capacity make it the perfect complement for any type of projects, contract or residential. Available in two heights 75 and 110cm.

ES Basic tables colección de mesas con base de acero recubierto de pintura epoxi. La base y el sobre están disponibles en redondo o cuadrado. Su diseño simple y audaz y su capacidad de personalización hacen que sea el complemento perfecto para cualquier tipo de proyecto, contract o residencial. Disponible en dos alturas 75 y 110cm.

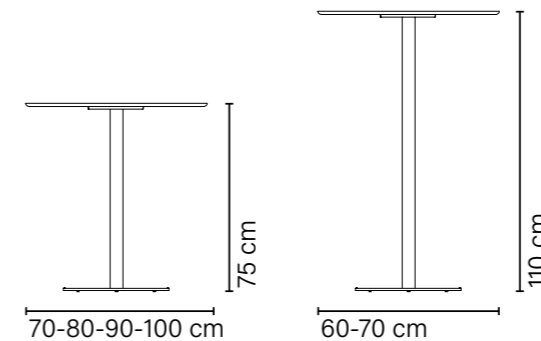



318

Tables /Mesas

capdell



319

capdell

Tables /Mesas



BASIC TABLES collection

Table / Mesa



TB74-O
 Round steel base with powder-coated finishing / Base redonda de acero con recubrimiento de pintura en polvo.



TB110-O
 Hight round steel base with powder-coated finishing / Base alta redonda de acero con recubrimiento de pintura en polvo.



TB74-C
 Square steel base with powder-coated finishing / Base cuadrada de acero con recubrimiento de pintura en polvo.



TB110-C
 Hight square steel base with powder-coated finishing / Base alta cuadrada de acero con recubrimiento de pintura en polvo.



Tables /Mesas

capdell

DROPLETS collection

Design by Claesson Koivisto Rune

EN Collection of benches and side tables with a light and elegant aesthetic. A minimalist design but with a presence that impacts the environment. The designers, the Claesson Koivisto Rune, were inspired by the shapes that droplets of water make when they land on a surface. The different models allow endless combinations that make this collection a set perfectly adaptable to common spaces, retail and hotels.

ES Colección de bancos y mesas auxiliares de estética ligera y elegante. Un diseño minimalista pero con una presencia que impacta en el entorno. Los diseñadores, los Claesson Koivisto Rune, se inspiraron en las formas que las gotas de agua componen al posarse sobre una superficie. Los distintos modelos permiten infinitas combinaciones que hacen de esta colección un conjunto perfectamente adaptable a espacios comunes, retail y hoteles.

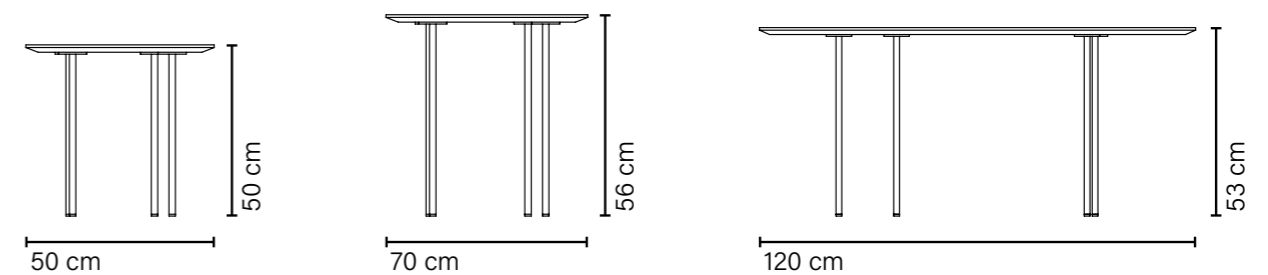

capdell

Tables /Mesas



324

325



DROPLETS collection

Table / Mesa



1801Y

Table with metal legs with chrome finish or epoxy paint and beech veneer top. / Mesa con patas de metal en acabado cromado o pintura epoxi y tablero chapado en haya.



1803Y

Table with metal legs with chrome finish or epoxy paint and beech veneer top. / Mesa con patas de metal en acabado cromado o pintura epoxi y tablero chapado en haya.



1805Y

Table with metal legs with chrome finish or epoxy paint and beech veneer top. / Mesa con patas de metal en acabado cromado o pintura epoxi y tablero chapado en haya.



Tables /Mesas

capdell

GUS collection

Design by Francesc Rifé

EN Collection of tables with a sober but at the same time balanced design. The feature that stands out most in Gus is, without a doubt, the revolutionary concrete base, which aims to merge with the urban landscape, transforming itself into an extension of the pavement. Both because of its strong personality and its ability to personalize, it is a table that can dress up any type of space.

ES Colección de mesas con un diseño sobrio pero al mismo tiempo equilibrado. El rasgo que más destaca en Gus es, sin lugar a dudas, la revolucionaria base de hormigón, que pretende fundirse con el paisaje urbano transformándose en una extensión del pavimento. Tanto por su fuerte personalidad como por su capacidad de personalización es una mesa que puede vestir cualquier tipo de espacio.

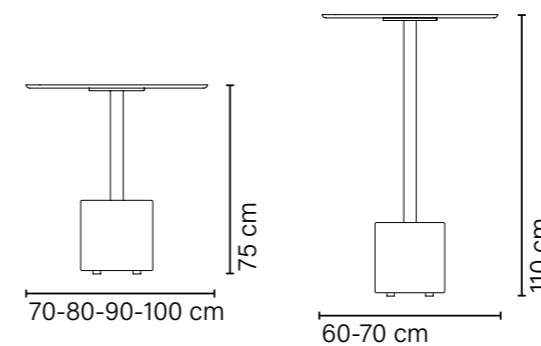

capdell

Tables /Mesas



330

Tables /Mesas

capdell



331

Tables /Mesas

capdell



332

Tables /Mesas

capdell



333

Tables /Mesas

capdell



GUS collection

Table / Mesa



TGU74

Table with concret and steel base. Round or square top / Base de cemento y acero con recubrimiento de pintura en polvo. Tapa redonda o cuadrada



TGU110

Hight table with concret and steel base. Round or square top / Base alta de cemento y acero con recubrimiento de pintura en polvo. Tapa redonda o cuadrada



Tables /Mesas

capdell

GAZELLE collection

Design by Claesson Koivisto Rune

EN Light, ethereal and very chic. A collection of tables with a pure and stylized design. The main characteristic of this collection is the subtle but sculptural morphology of the elegant legs, its design, made of anodized aluminum, is the result of a digital, fluid and gradual morphing of the transformation between a circle and a triangle. An exercise in refined elegance that eliminates mass and leaves only the essentials. Available in various sizes, shapes and materials. The legs can be finished in polished anodized aluminum or epoxy paint.

ES Ligera, etérea y muy chic. Una colección de mesas con un diseño puro y estilizado. La principal característica de esta colección es la sutil pero escultural morfología de las elegantes patas, su diseño, hecho en aluminio anodizado, es el resultado de un morphing digital, fluido y gradual de la transformación entre un círculo y un triángulo. Un ejercicio de refinada elegancia que elimina masa y deja solamente lo esencial. Disponible en varios tamaños, formas y materiales. El acabado de las patas puede ser en aluminio anodizado pulido o pintura epoxi.

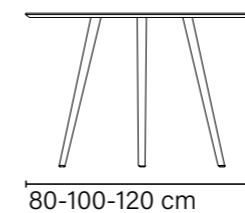

80-100-120 cm

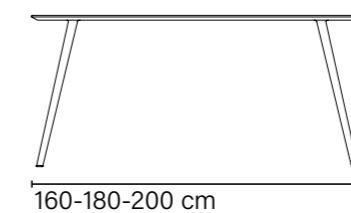

160-180-200 cm

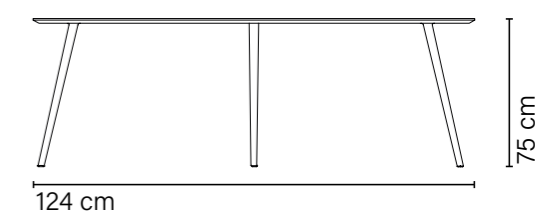

124 cm

75 cm

capdell

Tables /Mesas



338

339



GAZELLE collection

Table / Mesa



TG3

Aluminium legs are available in polished or powder coated. Round top / Patas de aluminio disponibles en pulido o recubrimiento en polvo. Tapa redonda



TG4

Aluminium legs are available in polished or powder coated. Oval top / Patas de aluminio disponibles en pulido o recubrimiento en polvo. Tapa oval



TG6

Aluminium legs are available in polished or powder coated. Oval top / Patas de aluminio disponibles en pulido o recubrimiento en polvo. Tapa oval



Tables /Mesas

Insula collection

Design by Patrick Norguet

EN This collection is a system of seats and tables that offer a simple and elegant solution for decorating common spaces. The designer, Patrick Norguet, wants the combination of the pieces in this collection to evoke natural landscapes. Much more than a set, Ínsula is first of all a system: it is made up of a basic structure on which the seats, backrests and accessories are fixed.

This project is conceived as a set of simple construction and combinations, without forgetting the main function, the comfort of its use.

ES Esta colección es un sistema de asientos y mesas que ofrecen una solución sencilla y elegante para vestir espacios comunes. El diseñador, Patrick Norguet, busca que con la combinación de las piezas de esta colección se evoque a los paisajes naturales. Mucho más que un conjunto, Ínsula es antes que nada, un sistema: se compone de una estructura básica sobre la cual se fijan los asientos, los respaldos y los accesorios. Se concibe este proyecto como un conjunto de construcción simple y de combinaciones, sin olvidar la función principal, la comodidad de su uso.

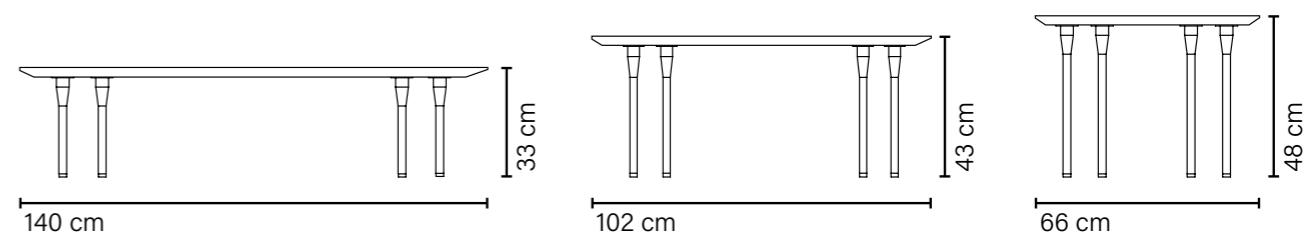

Tables /Mesas





INSULA collection

Table / Mesa



453
 Coffe table with steel legs and top in oak veener / Mesa con patas de acero y tapa de madera de roble



454
 Coffe table with steel legs and top in oak veener / Mesa con patas de acero y tapa de madera de roble



455
 Coffe table with steel legs and top in oak veener / Mesa con patas de acero y tapa de madera de roble



348

LIBRIS collection

Design by Vicent Martínez

EN The Libris table collection is inspired by books and how their leaves are made. This table is available in an extendable version and as a modular system to create wide compositions. The covers of the Libris extendable have a flexible and very resistant carbon fiber joint. The movement, turning and unfolding are inspired by the old Dutch gaming tables. The Libris system can be customized with a central channel with hinged covers that give easy access to the table's wiring and leave all the wiring hidden. This modular system allows the tables to be configured and dimensioned to equip all types of spaces, facilities, hotels, offices or residential places. Capdell's tradition, culture and taste for cabinetmaking are reflected in the curved and laminated arched wood that, together with the solid wood benches, support the laminated board tops.

ES La colección de mesas Libris se inspira en los libros y en cómo se conforman sus hojas. Esta mesa está en versión extensible y como sistema modular para crear amplias composiciones. Las tapas de la Libris extensible tienen una unión de fibra de carbono flexible y muy resistente. El movimiento, giro y desplegado se inspiran en las antiguas mesas de juego holandesas. El sistema Libris puede personalizarse con un canal central de tapas abatibles que dan fácil acceso al cableado de la mesa y dejan todo el cableado oculto. Este sistema modular permite configurar y dimensionar mesas para equipar todo tipo de espacios, instalaciones, hostelería, oficinas o lugares residenciales. La tradición, cultura y gusto por la ebanistería de Capdell se reflejan en los arcos de madera curvada y laminada que junto a las bancadas de madera maciza dan soporte a las tapas de tablero laminado.

349

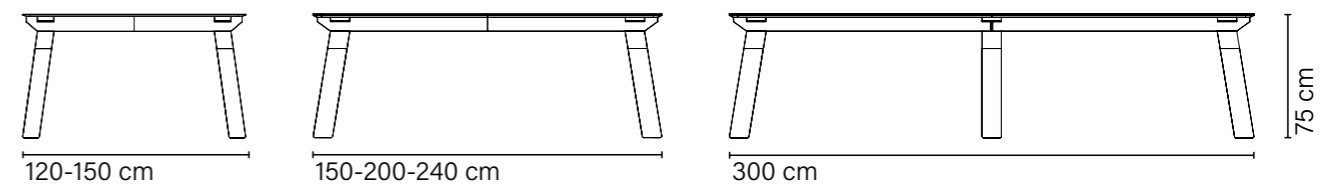



Tables /Mesas

capdell

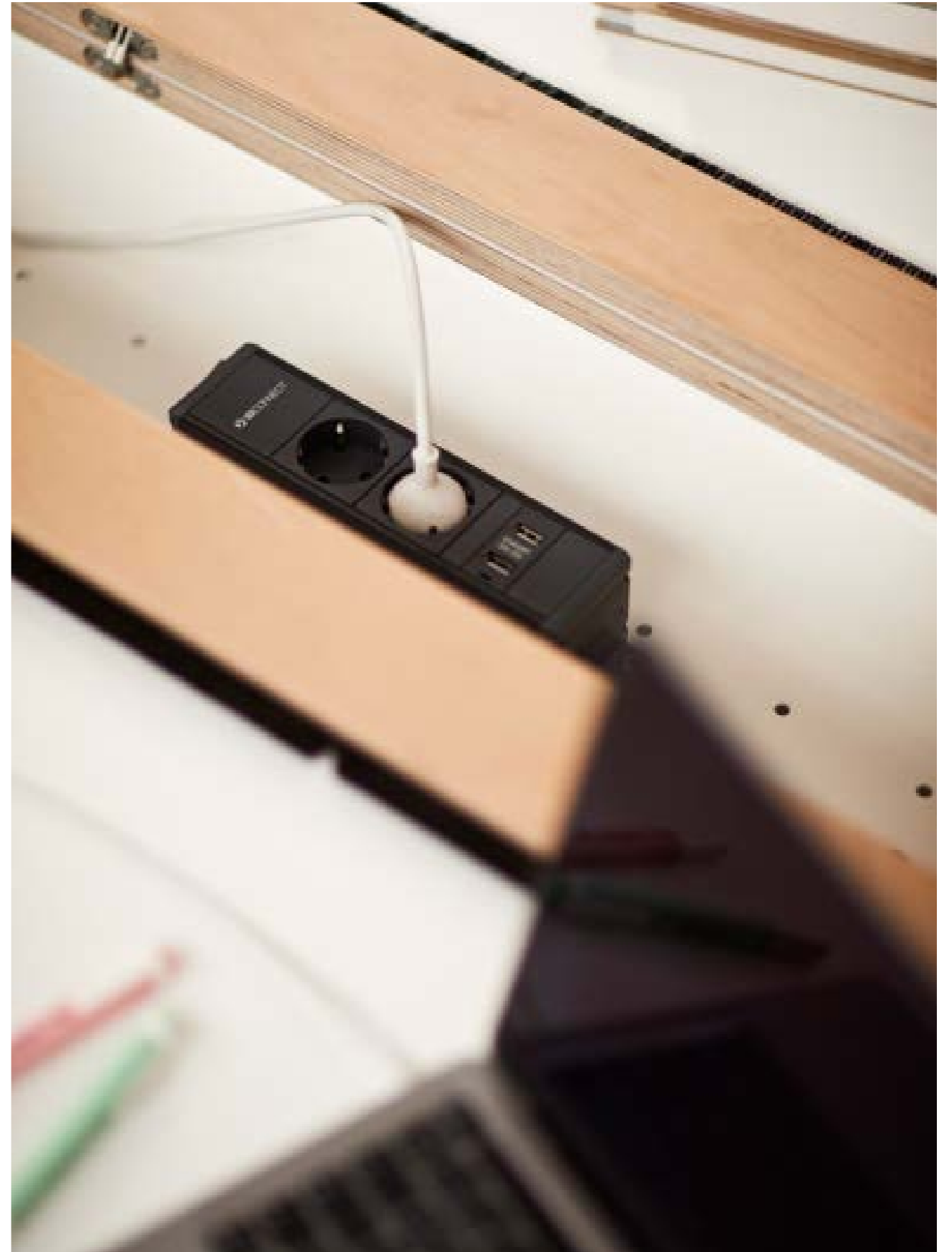

capdell

Tables /Mesas



352

353



354

355



356

Tables /Mesas

capdell



357

Tables /Mesas

capdell



LIBRIS collection

Table / Mesa



TL-90

Extensible table with oak or beech legs and structure. Top available in different finishes / Mesa extensible con patas y estructura de haya o roble. Tapa disponible en varios acabados



TL-100

Table with oak or beech legs and structure. Top available in different finishes / Mesa con patas y estructura de haya o roble. Tapa disponible en varios acabados



TLE

Electrified table with oak or beech legs and structure. Top available in different finishes / Mesa Electrificada con patas y estructura de haya o roble. Tapa disponible en varios acabados



TLE

Electrified table with oak or beech legs and structure. Top available in different finishes / Mesa Electrificada con patas y estructura de haya o roble. Tapa disponible en varios acabados



NOOK collection

Design by Mario Ruiz

EN Collection of tables, available in central foot and rod, both in 2 heights.

Table with a central foot, with a concrete base: The concrete base has a central hole where the tube is situated. The diameter of the concrete's hole is the same as the diameter of the tube, so there is a formal continuity.

The metal rod table, like the stool, has a marked character of symmetry, and plays with the tangency of the rod.

The top of the table is modular, it is made up of two pieces: a common lower board, which adds character with its bevelling and gives continuity to the top.

ES Colección de mesas, disponible en pie central y en varilla, ambas en 2 alturas.

Mesa de pie central, con base de hormigón: La base de hormigón tiene un agujero central donde se aloja el tubo. El diámetro de la boca del hormigón es el mismo que el diámetro del tubo, de modo que hay una continuidad formal.

La mesa de varilla metálica, al igual que el taburete, tiene marcado carácter de simetría, y juega con la tangencia de la varilla.

El top de la mesa es modular, está formado por dos piezas: un tablero inferior común, que aporta carácter con su biselado y da continuidad a la tapa.

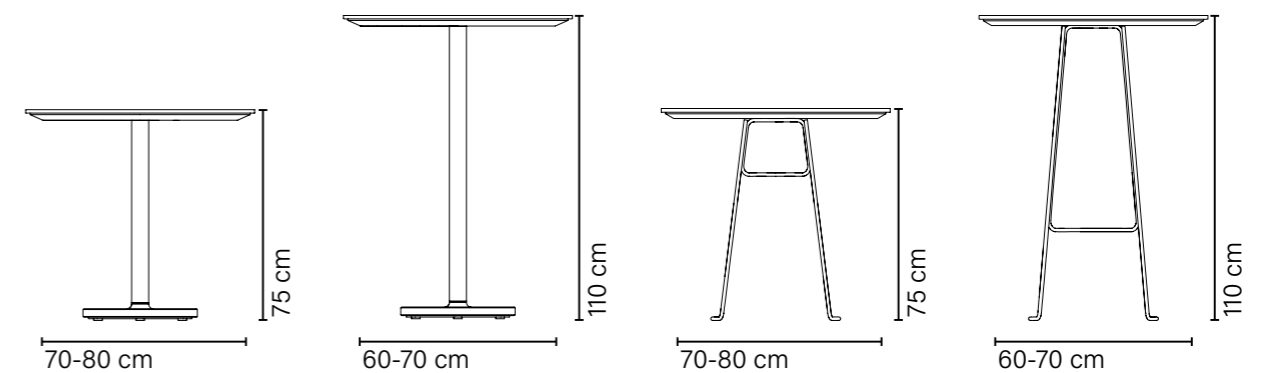



362



363





366

Tables /Mesas

capdell



367

Tables /Mesas

capdell



368

Tables /Mesas

capdell



369

Tables /Mesas

capdell



NOOK collection

Table / Mesa



TNC74
 Table with concret and steel base. Modular top, it is made up of two pieces / Mesa con base de cemento y acero. Tapa formada por dos piezas



TNC110
 Hight table with concret and steel base. Modular top, it is made up of two pieces / Mesa alta con base de cemento y acero. Tapa formada por dos piezas



TNV74
 Table with metal rod base. Modular top, it is made up of two pieces / Mesa con base de varilla de acero. Tapa formada por dos piezas



TNV110
 Hight table with metal rod base. Modular top, it is made up of two pieces / Mesa alta con base de varilla de acero. Tapa formada por dos piezas



372

MESANA collection

Design by Salvador Vallalba

EN A flexible and modular collection of tables, with its own personality, made up of two solid beech trestle and a HDF top. Its simplicity and versatility make it fit in any space, whether residential, contract or corporate. The detail of the insertion of the leg in the tabletop gives a distinctive touch to the collection while serving as a fixing for the tabletop, allowing it to be easily handled for assembly and disassembly without requiring the use of tools.

ES Colección de mesas flexible y modular, con una personalidad propia, compuesta por dos cabalotes de madera maciza de haya y sobre de HDF. Su sencillez y polivalencia hacen que encaje en cualquier espacio ya sea residencial, contract o corporativo. El detalle de la inserción de la pata en el tablero concede un toque distintivo a la colección a la vez que sirve de fijación para el tablero permitiendo su fácil manipulación para montaje y desmontaje sin requerir el empleo de herramientas.

373

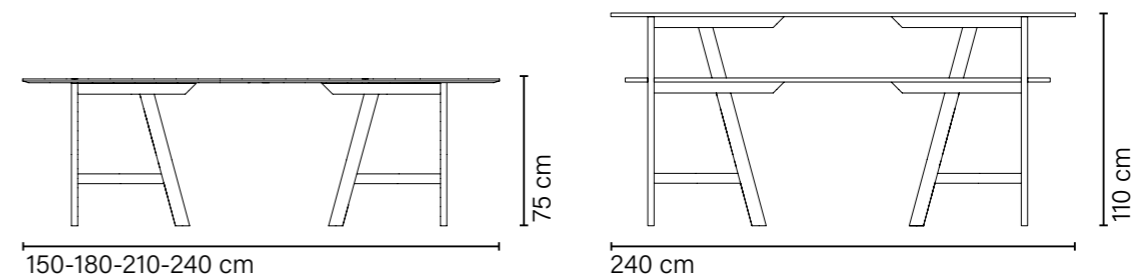



374

Tables /Mesas

capdell



375

Tables /Mesas

capdell



MESANA collection

Table / Mesa



TM74

Table with beech wood bases and HDF top / Mesa con patas de haya y tapa de HDF



TM110

Hight table with beech wood bases and HDF top / Mesa alta con patas de haya y tapa de HDF



378

MESANA DESK collection

Design by Patrick Norguet

EN On the basis of the MESANA collection, Patrick Norguet has developed a brand new small office desk for the residential market. A singular compact desk made in oak and available in different colours.

ES Partiendo de nuestra colección MESANA, Patrick Norguet ha desarrollado un escritorio para el hogar. Se trata de un escritorio compacto y de roble, disponible en varios colores.

379

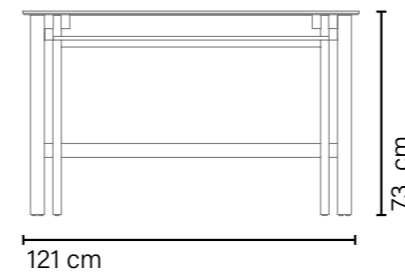



380



381



MESANA DESK collection

Table / Mesa



TMD74

Desk with oak wood structure and top / Escritorio con estructura y tapa de roble



TRISTAR collection

Design by Claesson Koivisto Rune

EN The Tri-Star table features a distinctive central foot made from three aluminum extrusions that form a 3-point star-shaped base. This collection has a high customization capacity. Its central column can be veneered in oak or painted in epoxy.

The structure supports tops of various sizes that make Tri-Star a useful collection for both home and contract. Available in two heights 75 and 55 cm.¹

ES La mesa Tri-Star presenta un peculiar pie central hecho de tres extrusiones de aluminio que conforman una base en forma estrellada de 3 puntas. Esta colección tiene una alta capacidad de personalización. Su columna central puede ir chapada en roble o pintada en epoxi.

La estructura soporta sobres de diversos tamaños que convierten a Tri-Star en una colección útil tanto para hogar como para contract. Disponible en dos alturas 75 y 55 cm.

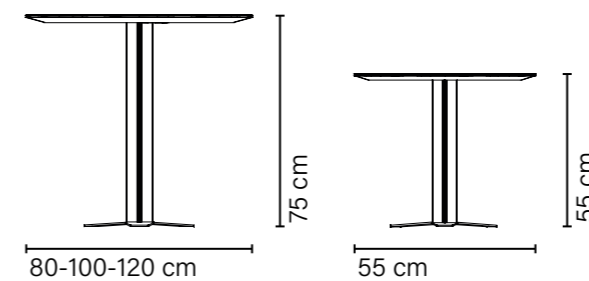



386

Tables /Mesas

capdell



387

Tables /Mesas

capdell



TRISTAR collection

Table / Mesa



TT74

Table with aluminium column, covered with laminated oak or epoxy painted / Mesa con una columna de aluminio chapada en roble o pintura epoxi



TT55

Table with aluminium column, covered with laminated oak or epoxy painted / Mesa con una columna de aluminio chapada en roble o pintura epoxi



W collection

Design by Gabriel Teixidó

EN W is a table with a striking 50mm diameter steel tube structure in epoxy paint and an extra-clear tempered glass top, a top that makes it an almost invisible part of the piece. Making the W a contemporary table both in terms of its shapes and its combination of materials. The main detail of this table are the V-shaped legs and the intersection that forms between them and the beams that support the top.

ES W es una mesa con una llamativa estructura de tubo de acero de 50mm de diámetro pintura epoxi y sobre de cristal extraclaro templado, un sobre que convierte en una parte casi invisible de la pieza. Haciendo de W una mesa contemporánea tanto por sus formas como por su combinación de materiales. El principal detalle de esta mesa son sus patas en V y la intersección que se forma entre las mismas y las vigas que soportan el sobre.

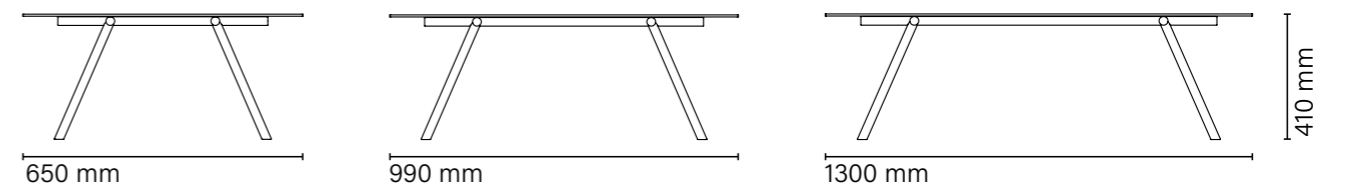



392

393



W collection

Table / Mesa



TW

Table with base of steel pipe covered
by epoxy Top of tempered glass.
/ Mesa con estructura de acero
recubierto de pintura epoxi. Tapa de
cristal templado

OUR SPACES /
NUESTROS ESPACIOS



A-collection and W table - Àtic en blanc by Fran Silvestre, Valencia, Spain





400



A-collection - Loft in Candy Beach, India

Spaces /
Espacios

capdell



401

A collection - Kouros tower

capdell

Spaces /
Espacios



Nix and Basic table - Restaurant Under the sea, St Petersburg, Russia





Moon - Jardines de Nivaria Hotel, Santa Cruz de Tenerife, Spain

Spaces /
Espacios

capdell



Aro - Jardines de Nivaria Hotel, Santa Cruz de Tenerife, Spain

capdell

Spaces /
Espacios



Aro - Artel' Bistro, Kazan, Russia

Spaces /
Espacios

capdell



capdell

Spaces /
Espacios



Aro - W Paris Opéra hotel restaurant, Paris, France

Spaces /
Espacios

capdell



Aro and Concord - Stena Line - Estrid

capdell

Spaces /
Espacios

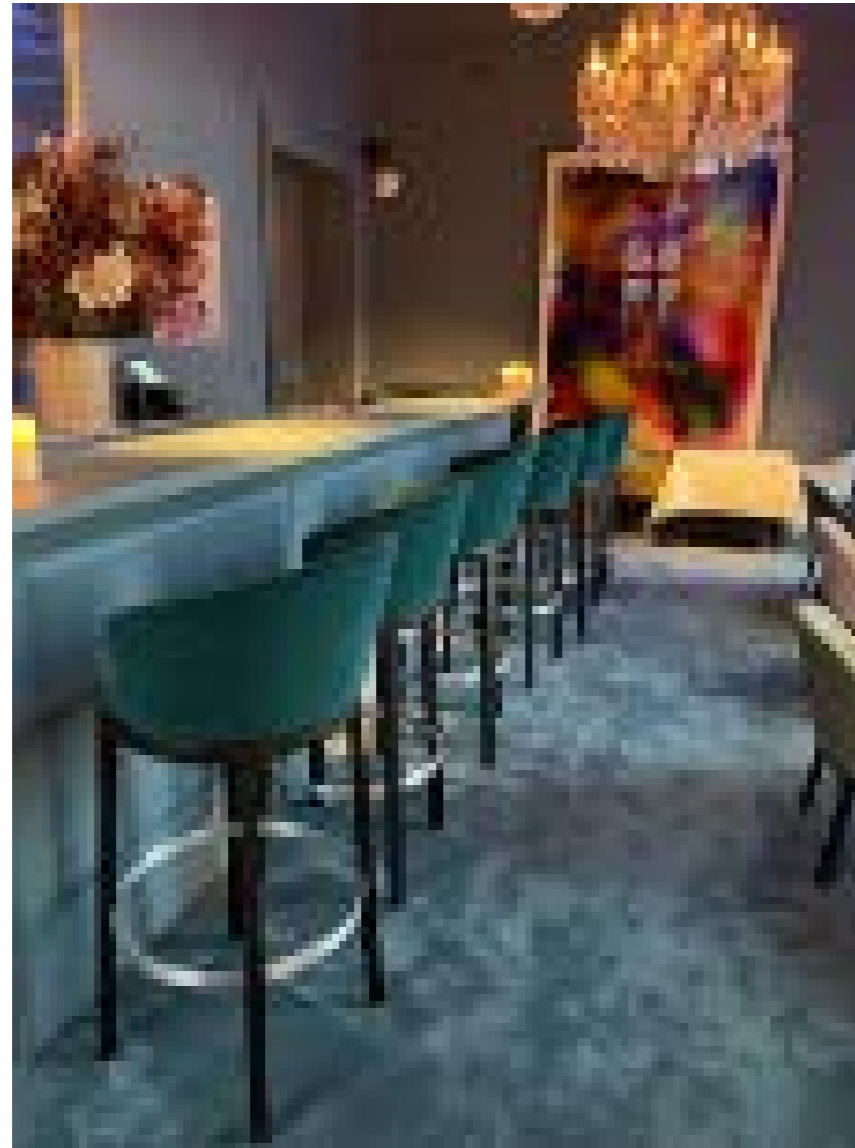

Aro - Merode Hotel, Brussels, Belgium



Aro and Basic table - Orovivo office, Berlin, Germany



Eco and Basic table - Gardiner Museum restaurant, Toronto, Canada



Eco and Concord - Courchevel restaurant, France

Spaces /
Espacios

capdell



Eco and Basic table - Vincci bar Centrum, Madrid, Spain

capdell

Spaces /
Espacios



Panel - Energy Company, Israel



Col - Cassette restaurant, Dubai, United Arab Emirates





420



Flick - Puri restaurant, Estonia

Spaces /
Espacios

capdell



421

Stir - Quorum restaurant, Jerez de la frontera, Spain

capdell

Spaces /
Espacios



Moon - Albarracín restaurant, Albarracín, Spain

Spaces /
Espacios

capdell



capdell

Spaces /
Espacios



Moon - Residential by Gallardo Arquitectos, Madrid, Spain

Spaces /
Espacios



Moon - Home, Madrid, Spain

Spaces /
Espacios



426

427

Concord - Casa Carmela restaurant, Valencia, Spain

Spaces /
Espacios

capdell

capdell

Spaces /
Espacios



Dual - Sheraton Hacienda del Álamo Golf & Spa Resort, Murcia, Spain

Spaces /
Espacios



Ava - Mel Beach restaurant, Mallorca, Spain

Spaces /
Espacios



Ulis and Insula tables - Corporate hall



Able, Loop, Plum, Aro and Bridge - Management office



Able, Loop, Plum, Aro and Bridge - Management office



Libris system, Loop and Vision - Office



438

439

Libris system, Loop and Vision - Office

Spaces /
Espacios

capdell

capdell

Spaces /
Espacios



Atoll, Nix and Gus - Amphitheatre in a coworking



Polo, Mesana and stool - Ideas lab

Credits / *Créditos*

Art direction and graphic design /

Dirección de arte y diseño gráfico

Alberto Diago

Photography / *Fotografía*

Cualiti Photo Studio

Art work / *Serigrafías*

Tramanda

Lightly / *Iluminaria*

Marset

LZF Lamps

Nistal

Printed in Impreso en Valencia

Copyright 2022 Capdell

All rights reserved / *Todos los derechos reservados*

www.capedell.com

capdell